

THIS DRAWING IS UNPUBLISHED. RELEASED FOR PUBLICATION  
 © COPYRIGHT 19 BY TYCO ELECTRONICS CORPORATION. ALL RIGHTS RESERVED.

LOC	DIST	REVISIONS			
P	LTR	DESCRIPTION	DATE	DWN	APVD
HQ	00	E	Update stamping for RoHS	27JAN2006	MAH MAH
		F	Modify element lengths	31OCT2006	APV MAH
		G	Modify element lengths	09JAN2007	VG MAH
		H	Modify element lengths	29JAN2007	DJL MAH

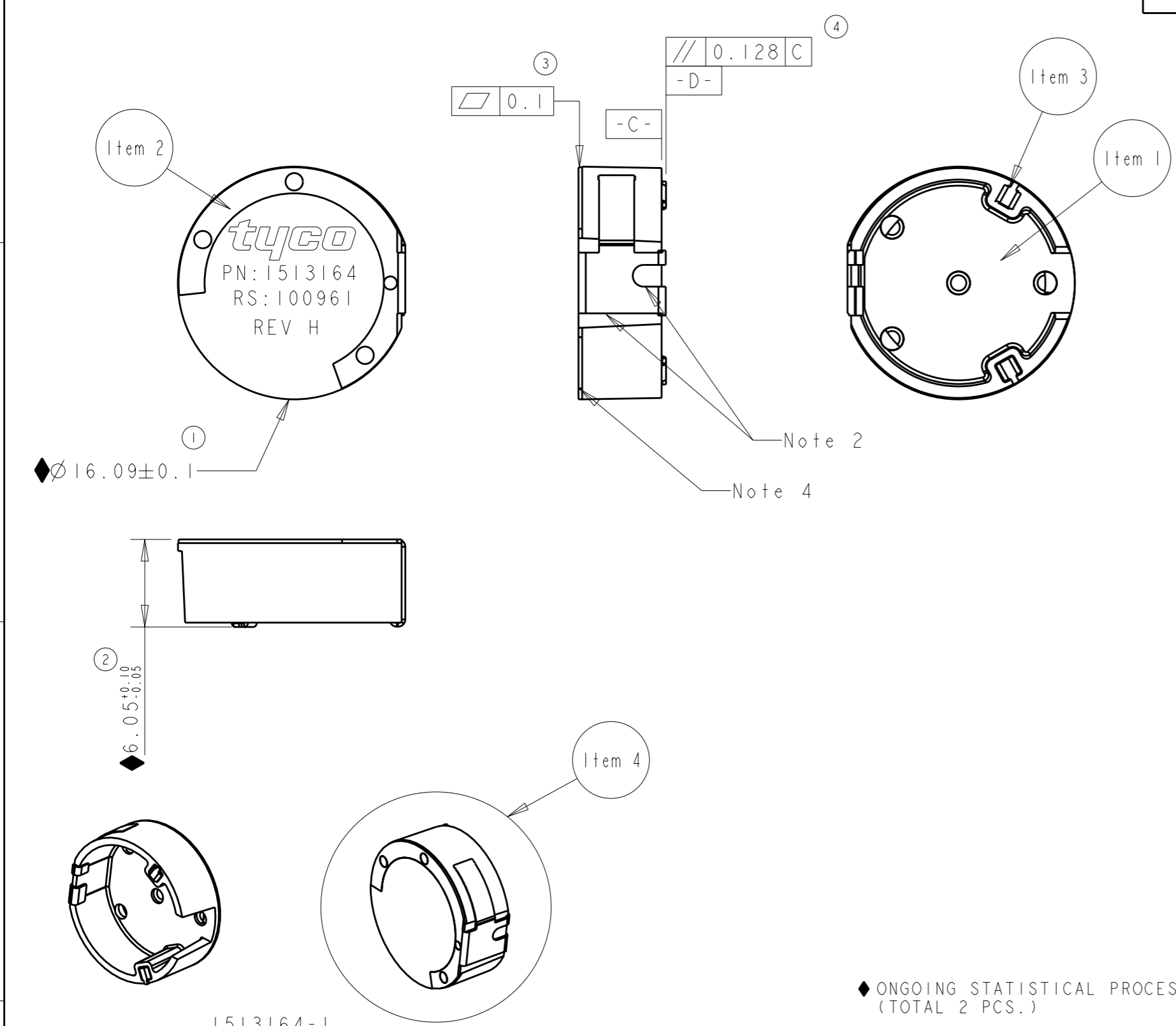

NOTES:

1. Material-Dupont HTN 52G30NH
2. Item 2 insert molded into item 1. Flat side wall of item 2 to be flush with flat side wall in item 1
3. Item 3 press fit into item 4.
4. No air gaps between components.
5. General tolerance block applies unless otherwise specified.
6. Part is compliant to RoHS standards per Tyco Standard 230 - 702

◆ ONGOING STATISTICAL PROCESS CONTROL REQUIRED (TOTAL 2 PCS.)

ITEM NO.	QTY.	PART NO.	DESCRIPTION
1	1	1513164-4	OVERMOLDED METAL RING
2	1	1513164-3	METAL RING
3	2	1513167-1	ANCHOR TAB
4	1	1513164-1	ASSEMBLY

1513164-1  
SCALE 2:1

<small>THIS DRAWING IS A CONTROLLED DOCUMENT FOR TYCO ELECTRONICS CORPORATION. IT IS SUBJECT TO CHANGE AND THE CONTROLLING ENGINEERING ORGANIZATION SHOULD BE CONTACTED FOR THE LATEST REVISION.</small>		DWN MAH 29-Jan-07	Tyco Electronics Rochester, New York 14623	
DIMENSIONS: mm 		CHK -		
TOLERANCES UNLESS OTHERWISE SPECIFIED: 0 PLC ±0.10 1 PLC ±0.10 2 PLC ±0.05 3 PLC ±0.05 4 PLC ±0.01 ANGLES ±1°		APVD -	2.4/5 GHz Dual Band Antenna	
MATERIAL -		PRODUCT SPEC -	SIZE A3	CAGE CODE 00779
FINISH -		APPLICATION SPEC -	DRAWING NO. C-1513164	RESTRICTED TO -
		WEIGHT -	SCALE 3:1 SHEET 1 OF 1 REV H	
CUSTOMER DRAWING				