

THIS DRAWING IS UNPUBLISHED.

RELEASED FOR PUBLICATION

ALL RIGHTS RESERVED.

COPYRIGHT

REVISIONS

LTR	DESCRIPTION	DATE	DWN	APVD
C	REVISED PER ECO-14-016770	07NOV2014	NK	RH

NOTES:

1. 1.60 MAX FLASH PERMITTED.

WEDGE LENGTH

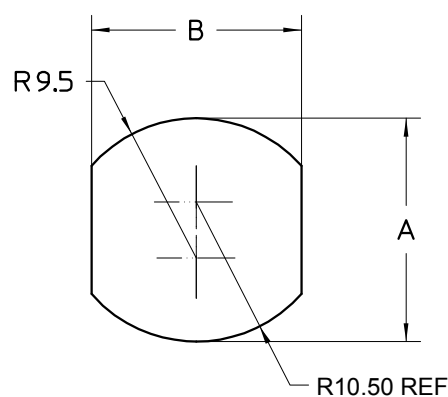
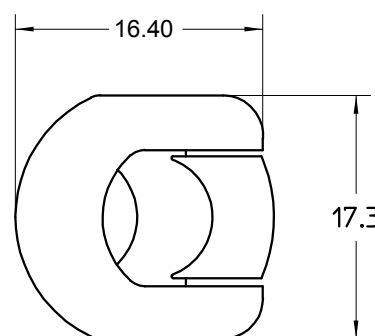
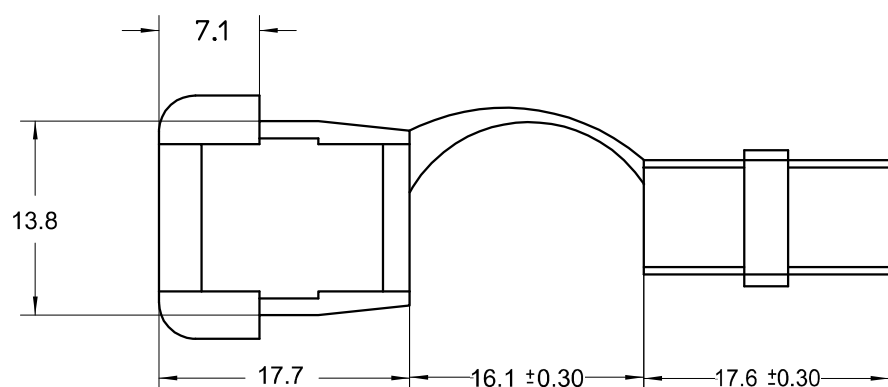
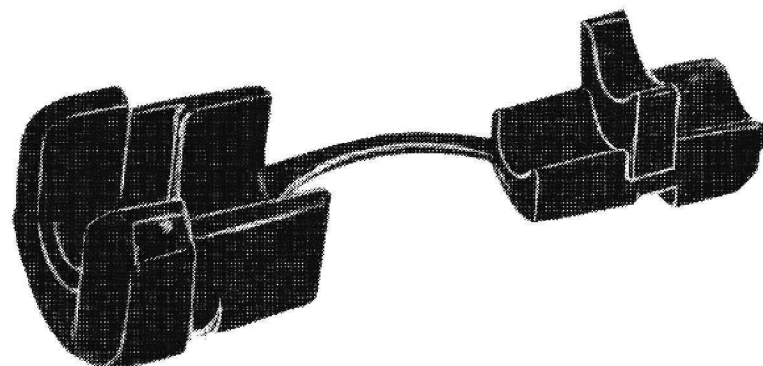
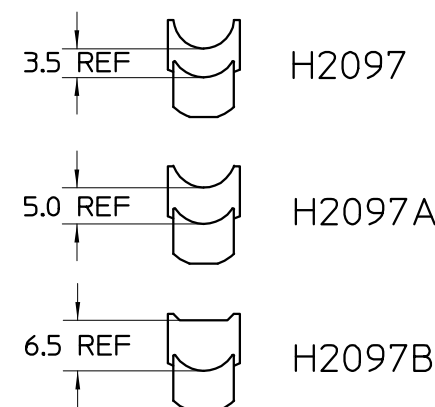

MOUNTING APERTURE

NOTE: SUITABLE FOR PANEL THICKNESS UP TO 2mm

* DATA IN THIS TABLE SHOULD BE USED FOR GUIDANCE ONLY. DUE TO DIFFERING CABLE MATERIALS AND STRUCTURES, THE SELECTED GROMMET AND APERTURE SIZE SHOULD BE VERIFIED BY PRACTICAL EXPERIMENTATION BEFORE DESIGN IS FINALISED.

9.8-10.3	CORD GRIP GROMMET (H2097)	1-1627229-7	17.3	14.7
8.5-9.7	CORD GRIP GROMMET (H2097A)	1-1627229-2	17.3	14.7
6.4-8.4	CORD GRIP GROMMET (H2097A)	1-1627229-2	15.2	14.3
5.9-6.3	CORD GRIP GROMMET (H2097B)	1-1627229-4	15.2	14.3
CABLE O/D*	DESCRIPTION	PART No	A	B
			APERTURE*	

THIS DRAWING IS A CONTROLLED DOCUMENT.		DWN: M. INSTANCE 12 FEB 08											
ALL DIMENSIONS IN mm:		CHK: H. THAI 12 FEB 08											
<p>TOLERANCES UNLESS OTHERWISE SPECIFIED:</p> <table border="1"> <thead> <tr> <th>DIMENSION(mm)</th> <th>TOLERANCE(mm)</th> </tr> </thead> <tbody> <tr> <td>LESS THAN 10</td> <td>+0.20</td> </tr> <tr> <td>OVER 10 TO 30</td> <td>+0.30</td> </tr> <tr> <td>OVER 30 TO 80</td> <td>+0.45</td> </tr> </tbody> </table>		DIMENSION(mm)	TOLERANCE(mm)	LESS THAN 10	+0.20	OVER 10 TO 30	+0.30	OVER 30 TO 80	+0.45	APVD: W. RIEDE 12 FEB 08	NAME:		
DIMENSION(mm)	TOLERANCE(mm)												
LESS THAN 10	+0.20												
OVER 10 TO 30	+0.30												
OVER 30 TO 80	+0.45												
		PRODUCT SPEC:	CORD GRIP GROMMET (H2097)										
MATERIAL: BLACK NYLON		APPLICATION SPEC:	SIZE: A3	CAGE CODE:	DRAWING NO: C-1627229								
FINISH: -		WEIGHT: -	RESTRICTED TO: -		SCALE: NTS								
CUSTOMER DRAWING			SHEET: 1	OF: 1	REV: C								