Shielded Top Entry Compliant Pin Modular Jack

1. SCOPE

1.1. Content

This specification covers performance, tests and quality requirements for the Tyco Electronics Shielded Top Entry Compliant Pin Modular Jack.

1.2. Qualification

When tests are performed on the subject product line, procedures specified in Figure 1 shall be used. All inspections shall be performed using the applicable inspection plan and product drawing.

1.3. Qualification Test Results

Successful qualification testing on the subject product line was completed on 28Oct01. The Qualification Test Report number for this testing is 501-91-6. This documentation is on file at and available from Engineering Practices and Standards (EPS).

2. APPLICABLE DOCUMENTS

The following documents form a part of this specification to the extent specified herein. Unless otherwise specified, the latest edition of the document applies. In the event of conflict between the requirements of this specification and the product drawing, the product drawing shall take precedence. In the event of conflict between the requirements of this specification and the referenced documents, this specification shall take precedence.

2.1. Tyco Electronics Documents

- 108-1163: Product Specification
- 109-197: AMP Test Specifications vs EIA and IEC Test Methods
- 114-6016: Application Specification
- 114-6053: Application Specification
- 501-91-6 Qualification Test Report

2.2. Industry Standards

- EIA-364: Electrical Connector/Socket Test Procedures Including Environmental Classifications
- ANSI/EIA/TIA 568, Appendix A: Reliability of Connecting Hardware Used For 100 ohm UTP Cabling

3. REQUIREMENTS

3.1. Design and Construction

Product shall be of the design, construction and physical dimensions specified on the applicable product drawing.

3.2. Materials

Materials used in the construction of this product shall be as specified on the applicable product drawing.

3.3. Ratings

- Voltage: 150 volts AC
- Current: Signal application only
- Temperature: -40 to 85°C

3.4. Performance and Test Description

Product is designed to meet the electrical, mechanical and environmental performance requirements specified in Figure 1. Unless otherwise specified, all tests shall be performed at ambient environmental conditions per EIA-364.

3.5. Test Requirements and Procedures Summary

| Test Description | Requirement | Procedure |
|---------------------------------|---|---|
| Initial examination of product. | Meets requirements of product drawing. | EIA-364-18. Visual and dimensional (C of C) inspection per product drawing. |
| Final examination of product. | Meets visual requirements. | EIA-364-18. Visual inspection. |
| ELECTRICAL | | |
| Low level contact resistance. | ΔR 30 milliohms maximum. | EIA-364-23. Subject specimens to 100 milliamperes maximum and 20 millivolts maximum open circuit voltage. See Figure 3. |
| Insulation resistance. | 500 megohms minimum. | EIA-364-21. Test between adjacent contacts of mated specimens. |
| Withstanding voltage. | 1 minute hold with no breakdown or flashover. | EIA-364-20, Condition I. 1000 volts AC at sea level. Test between adjacent contacts of mated specimens. |
| Crosstalk (NEXT). | See Figure 4. | EIA/TIA 568-A, Oct 1995. |
| Attenuation. | See Figure 4. | EIA/TIA 568-A, Oct 1995. |
| Return loss. | See Figure 4. | EIA/TIA 568-A, Oct 1995. |

Figure 1 (cont)

| Test Description | Requirement | Procedure |
|--|--|---|
| MECHANICAL | | |
| Vibration, sinusoidal. | No discontinuities of 1 microsecond or longer duration. See Note. | EIA-364-28, Test Condition I. Subject mated specimens to 10-55-10 Hz traversed in 1 minute with 1.5 mm [.06 in] maximum total excursion. 2 hours in each of 3 mutually perpendicular planes. See Figure 5. |
| Mechanical shock. | No discontinuities of 1 microsecond or longer duration. See Note. | EIA-364-27, Method H. Subject mated specimens to 30 G's half-sine shock pulses of 11 milliseconds duration. 3 shocks in each direction applied along 3 mutually perpendicular planes, 18 total shocks. See Figure 5. |
| Durability. | See Note. | EIA-364-9. Mate and unmate specimens for 750 cycles at a maximum rate of 600 cycles per hour. |
| Mating force. | 35.59 N [8 lbf] maximum. | EIA-364-13. Measure force necessary to mate specimens with latch depressed at a maximum rate of 12.7 mm [.5 in] per minute. |
| Unmating force. | 35.59 N [8 lbf] maximum. | EIA-364-13. Measure force necessary to unmate specimens with latch depressed at a maximum rate of 12.7 mm [.5 in] per minute. |
| Plug retention in jack. | Plug shall not dislodge from jack. | EIA-364-98. Apply an axial load of 88.96 N [20 lbf] to the plug housing at a rate of 12.7 mm [.5 in] per minute with plug mated in unmounted jack and latch engaged. |
| Pull. | Plug shall remain mated. See Note. | Load cable in a plug mated to an unmounted jack with a 75.62 N [17 lbf] pull in an axial direction, rotate the plug 45 degrees from cable axis, remove load. See Figure 6. |
| Jack retention to printed circuit board. | Jack shall not dislodge from printed circuit board. | Apply a 88.96 N [20 lbf] minimum perpendicular load at a rate of 50.8 mm [2 in] per minute to the jack mounted on a 1.57 mm [.062 in] thick printed circuit board. See Figure 6. |

Figure 1 (cont)

| Test Description | Requirement | Procedure |
|-------------------------------|-------------|---|
| ENVIRONMENTAL | | |
| Thermal shock. | See Note. | EIA-364-32. Subject mated specimens to 5 cycles between -40 and 85°C. |
| Humidity-temperature cycling. | See Note. | EIA-364-31, Method III. Subject mated specimens to 10 cycles (10 days) between 25 and 65°C at 80 to 100% RH. |
| Temperature life. | See Note. | EIA-364-17, Method A, Test Condition 3, Test Time Condition C. Subject mated specimens to 85°C for 500 hours. |
| Mixed flowing gas. | See Note. | EIA-364-65, Class IIA (4 gas). Subject mated specimens to environmental Class IIA for 20 days. |

NOTE *Shall meet visual requirements, show no physical damage, and meet requirements of additional tests as specified in the Product Qualification and Requalification Test Sequence shown in Figure 2.*

Figure 1 (end)

3.6. Product Qualification and Requalification Test Sequence

| Test or Examination | Test Group (a) | | | | | |
|---|-------------------|------|------|-----|---|---|
| | 1 | 2 | 3 | 4 | 5 | 6 |
| | Test Sequence (b) | | | | | |
| Initial examination of product | 1 | 1 | 1 | 1 | 1 | 1 |
| Low level contact resistance | 3,7 | 2,4 | 2,4 | | | |
| Insulation resistance | | | | 2,6 | | |
| Withstanding voltage | | | | 3,7 | | |
| Crosstalk | | | | | | 2 |
| Attenuation | | | | | | 3 |
| Return Loss | | | | | | 4 |
| Vibration | 5 | | | | | |
| Mechanical shock | 6 | | | | | |
| Durability | 4 | | | | | |
| Mating force | 2 | | | | | |
| Unmating force | 8 | | | | | |
| Plug retention in jack | | | | | 3 | |
| Pull | | | | | 2 | |
| Jack retention to printed circuit board | 9 | | | | | |
| Thermal shock | | | | 4 | | |
| Humidity-temperature cycling | | | | 5 | | |
| Temperature life | | 3(c) | | | | |
| Mixed flowing gas | | | 3(c) | | | |
| Final examination of product | 10 | 5 | 5 | 8 | 4 | 5 |

NOTE (a) See paragraph 4.1.A.
 (b) Numbers indicate sequence in which tests are performed.
 (c) Precondition specimens with 10 durability cycles.

Figure 2

4. QUALITY ASSURANCE PROVISIONS

4.1. Qualification Testing

A. Specimen Selection

Specimens shall be prepared in accordance with applicable Instruction Sheets and shall be selected at random from current production. All test groups shall each consist of 10, 8 position plugs and jacks.

B. Test Sequence

Qualification inspection shall be verified by testing specimens as specified in Figure 2.

4.2. Requalification Testing

If changes significantly affecting form, fit or function are made to the product or manufacturing process, product assurance shall coordinate requalification testing, consisting of all or part of the original testing sequence as determined by development/product, quality and reliability engineering.

4.3. Acceptance

Acceptance is based on verification that the product meets the requirements of Figure 1. Failures attributed to equipment, test setup or operator deficiencies shall not disqualify the product. If product failure occurs, corrective action shall be taken and specimens resubmitted for qualification. Testing to confirm corrective action is required before resubmittal.

4.4. Quality Conformance Inspection

The applicable quality inspection plan shall specify the sampling acceptable quality level to be used. Dimensional and functional requirements shall be in accordance with the applicable product drawing and this specification.

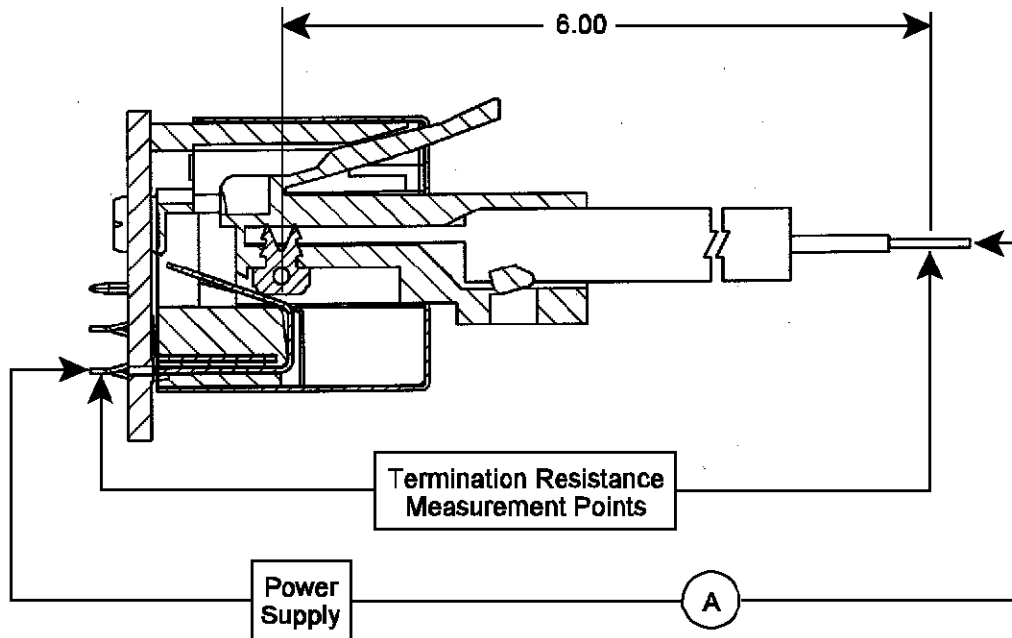

Figure 3
Low Level Contact Resistance Measurement Points

Category 5, 100 Ohm Twisted Pair

| Frequency (MHz) | NEXT Loss (dB) | Attenuation (dB) | Return Loss (dB) |
|-----------------|----------------|------------------|------------------|
| 1.00 | 65 | 0.1 | 23 |
| 4.00 | 65 | 0.1 | 23 |
| 8.00 | 62 | 0.1 | 23 |
| 10.00 | 60 | 0.1 | 23 |
| 16.00 | 56 | 0.2 | 23 |
| 20.00 | 54 | 0.2 | 23 |
| 25.00 | 52 | 0.2 | 14 |
| 31.25 | 50 | 0.2 | 14 |
| 62.50 | 44 | 0.3 | 14 |
| 100.00 | 40 | 0.4 | 14 |

NOTE See EIA/TIA 568-A, Oct. 1995

Figure 4

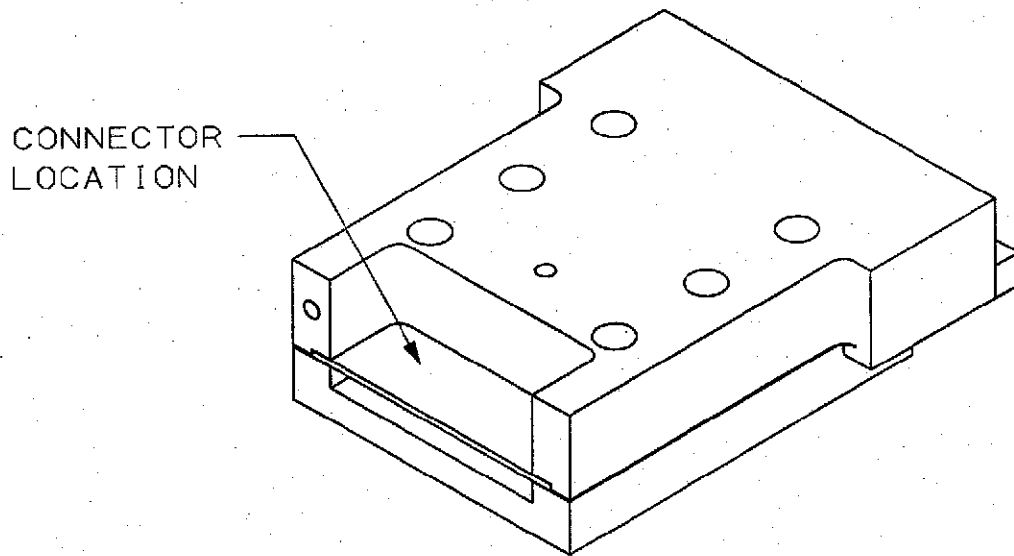

Figure 5
Vibration & Mechanical Shock Mounting Fixture

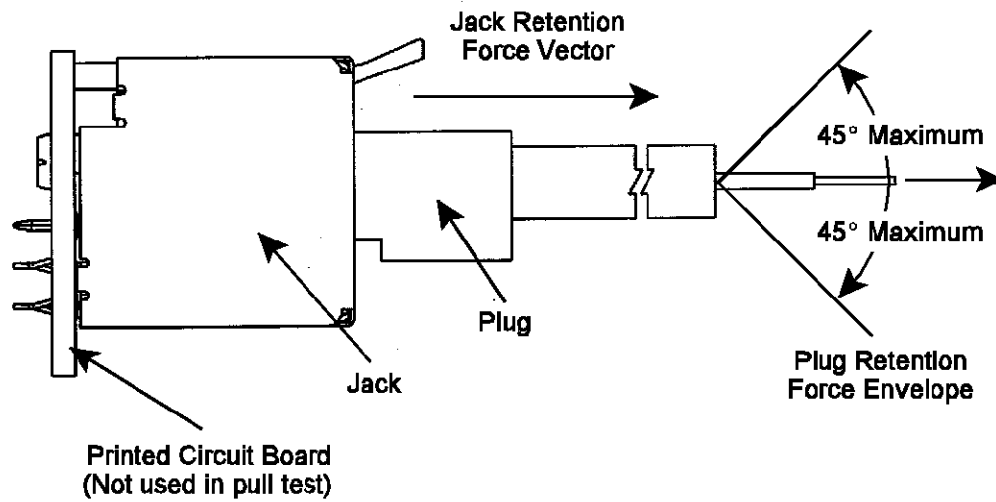

Figure 6
Plug & Jack Retention Forces