

Dual Beam Shunt**1. SCOPE**

1.1. Content

This specification covers the performance, tests and quality requirements for the Tyco Electronics dual beam shunt connector. This connector is a separable electrical connection device for mating with 2, .025 inch square posts. When used in normal applications, the centerline spacing between posts shall be .100 inch.

1.2. Qualification

When tests are performed on the subject product line, procedures specified in Figure 1 shall be used. All inspections shall be performed using the applicable inspection plan and product drawing.

1.3. Qualification Test Results

Successful qualification testing on the subject product line was completed on 30Oct97. The test file number for this testing is 501-380. This documentation is on file at and available from Engineering Practices and Standards (EPS).

2. APPLICABLE DOCUMENTS

The following Tyco Electronics documents form a part of this specification to the extent specified herein. Unless otherwise specified, the latest edition of the document applies. In the event of conflict between the requirements of this specification and the product drawing, the product drawing shall take precedence. In the event of conflict between the requirements of this specification and the referenced documents, this specification shall take precedence.

- 109-1: Test Specification (General Requirements for Test Specifications)
- 109 Series: Test Specifications as indicated in Figure 1
- 114-1059: Application Specification (Low Profile, Economy, Dual Beam, and Multiposition Shunt Connectors)
- 501-380: Qualification Test Report (Dual Beam Shunt)

3. REQUIREMENTS

3.1. Design and Construction

Product shall be of the design, construction and physical dimensions specified on the applicable product drawing.

3.2. Materials

Materials used in the construction of this product shall be as specified on the applicable product drawing.

3.3. Ratings

- Voltage: 250 volts AC
- Current: See Figure 5 for applicable current carrying capability
- Temperature: -65 to 105°C

3.4. Performance and Test Description

Product is designed to meet the electrical, mechanical and environmental performance requirements specified in Figure 1. Unless otherwise specified, all tests shall be performed at ambient environmental conditions per Test Specification 109-1.

3.5. Test Requirements and Procedures Summary

Test Description	Requirement	Procedure
Examination of product.	Meets requirements of product drawing and Application Specification 114-1059.	Visual, dimensional and functional per applicable quality inspection plan.
ELECTRICAL		
Termination resistance.	20 milliohms maximum initial. Maximum/minimum ΔR 10 milliohms per contact pair.	Test Spec 109-6-6. Subject mated contacts assembled in housing to 20 millivolts maximum open circuit at 100 milliamperes maximum. See Figure 3.
Insulation resistance.	10,000 megohms minimum initial.	Test Spec 109-28-4. Test between adjacent contacts of mated samples. See Figure 4.
Dielectric withstanding voltage.	1 minute hold with no breakdown or flashover.	Test Spec 109-29-1. 1000 volts AC at sea level. Test between adjacent contacts of mated samples. See Figure 4.
Temperature rise vs current.	30°C maximum temperature rise at specified current.	Test Spec 109-45-1. Measure temperature rise vs current. See Figures 3 and 5.
MECHANICAL		
Vibration, sinusoidal.	No discontinuities of 1 microsecond or longer duration. See Note.	Test Spec 109-21-3. Subject mated samples to 10-2000-10 Hz traversed in 20 minutes with .06 inch maximum excursion. Four hours in each of 3 mutually perpendicular planes. See Figure 6.
Physical shock.	No discontinuities of 1 microsecond or longer duration. See Note.	Test Spec 109-26-9. Subject mated samples to 100 G's sawtooth shock pulses of 6 milliseconds duration. Three shocks in each direction applied along 3 mutually perpendicular planes, 18 total shocks. See Figure 6.

Figure 1 (continued)

Test Description	Requirement	Procedure
Durability.	See Note.	Test Spec 109-27. Mate and unmate samples for 25 cycles at a maximum rate of 600 cycles per hour.
Mating force.	25 ounces maximum per contact pair.	Test Spec 109-42, Condition A. Measure force necessary to mate samples to post headers at a maximum rate of .5 inch per minute.
Unmating force.	1.25 ounces minimum per contact pair.	Test Spec 109-42, Condition A. Measure force necessary to unmate samples at a maximum rate of .5 inch per minute.

ENVIRONMENTAL

Thermal shock.	See Note.	Test Spec 109-22. Subject mated samples to 5 cycles between -65 and 105°C.
Humidity-temperature cycling.	See Note.	Test Spec 109-23-3, Condition B. Subject mated samples to 10 cycles between 25 and 65°C at 95% RH.
Temperature life.	See Note.	Test Spec 109-43. Subject mated samples to temperature life at 105°C for 96 hours.
Mixed flowing gas.	See Note.	Test Spec 109-85-3. Subject mated samples to environmental class III for 20 days.

NOTE

Shall meet visual requirements, show no physical damage and shall meet requirements of additional tests as specified in Test Sequence in Figure 2.

Figure 1 (end)

3.6. Product Qualification and Requalification Test Sequence

Test or Examination	Test Group (a)		
	1	2	3
	Test Sequence (b)		
Examination of product	1,9	1,9	1,8
Termination resistance	3,7	2,7	
Insulation resistance			2,6
Dielectric withstanding voltage			3,7
Temperature rise vs current		3,8(c)	
Vibration	5	6(d)	
Physical shock	6		
Durability	4		
Mating force	2		
Unmating force	8		
Thermal shock			4
Humidity-temperature cycling			5
Temperature life		5	
Mixed flowing gas		4(e)	

NOTE

- (a) See paragraph 4.1.A.
- (b) Numbers indicate sequence in which tests are performed.
- (c) Measure current with shunt configuration loaded single, 50%, and 100% up to 30°C temperature rise per Figure 5A.
- (d) Discontinuities shall not be measured. Energize at 18°C level for 100% loadings per Test Specification 109-151.
- (e) Precondition samples with 2 cycles durability.

Figure 2

4. QUALITY ASSURANCE PROVISIONS

4.1. Qualification Testing

A. Sample Selection

Samples shall be prepared in accordance with applicable Instruction Sheets and shall be selected at random from current production. All test groups shall each consist of a minimum of 30 samples. All shunts shall be mated to .025 inch square posts for testing. Square post headers may be mounted to printed circuit boards PN 93-660447.

B. Test Sequence

Qualification inspection shall be verified by testing samples as specified in Figure 2.

4.2. Requalification Testing

If changes significantly affecting form, fit or function are made to the product or manufacturing process, product assurance shall coordinate requalification testing, consisting of all or part of the original testing sequence as determined by development/product, quality and reliability engineering.

4.3. Acceptance

Acceptance is based on verification that the product meets the requirements of Figure 1. Failures attributed to equipment, test setup or operator deficiencies shall not disqualify the product. When product failure occurs, corrective action shall be taken and samples resubmitted for qualification. Testing to confirm corrective action is required before resubmittal.

4.4. Quality Conformance Inspection

The applicable quality inspection plan will specify the sampling acceptable quality level to be used. Dimensional and functional requirements shall be in accordance with the applicable product drawing and this specification.

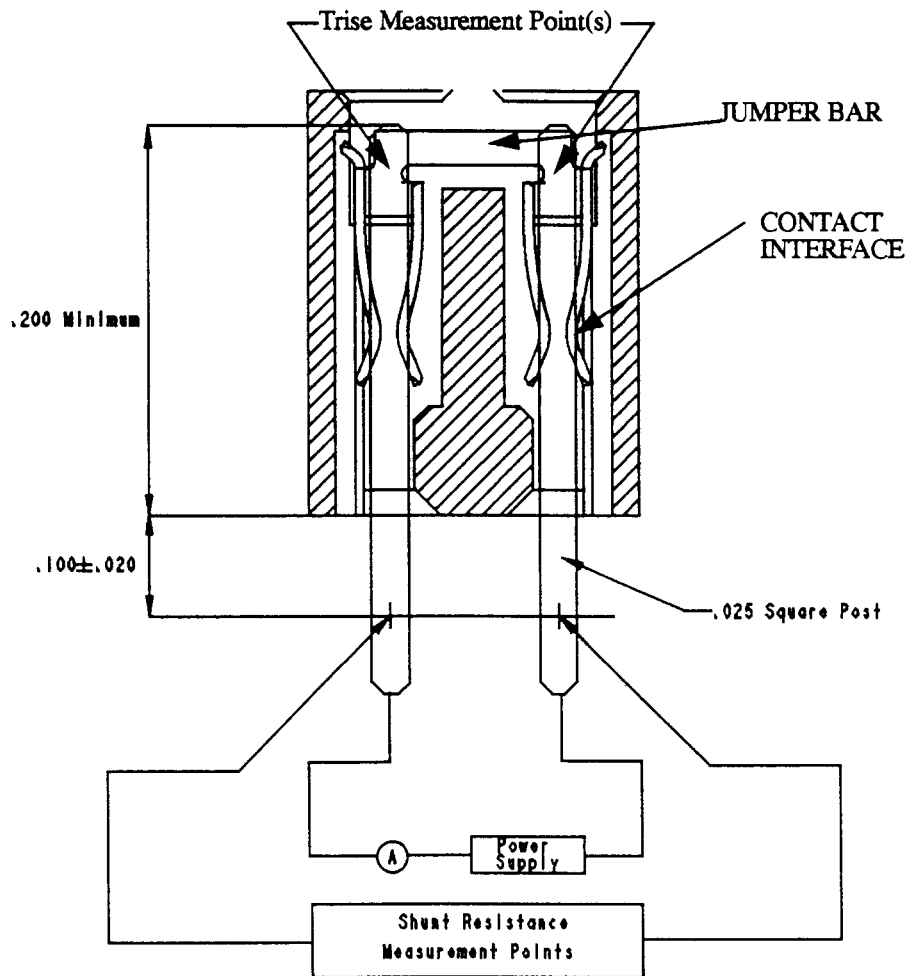

NOTE Post plating shall be identical to shunt plating when conducting tests.

Figure 3
Termination Resistance & Temperature Rise Measurement Points

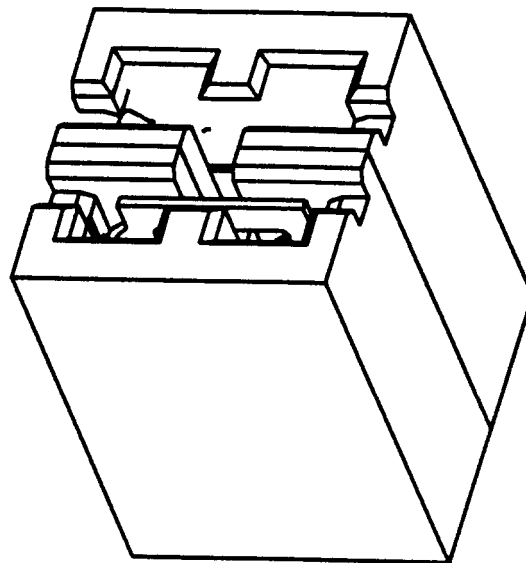

Figure 4
Adjacent Shunt Position For Dielectric Withstanding Voltage & Insulation Resistance Tests

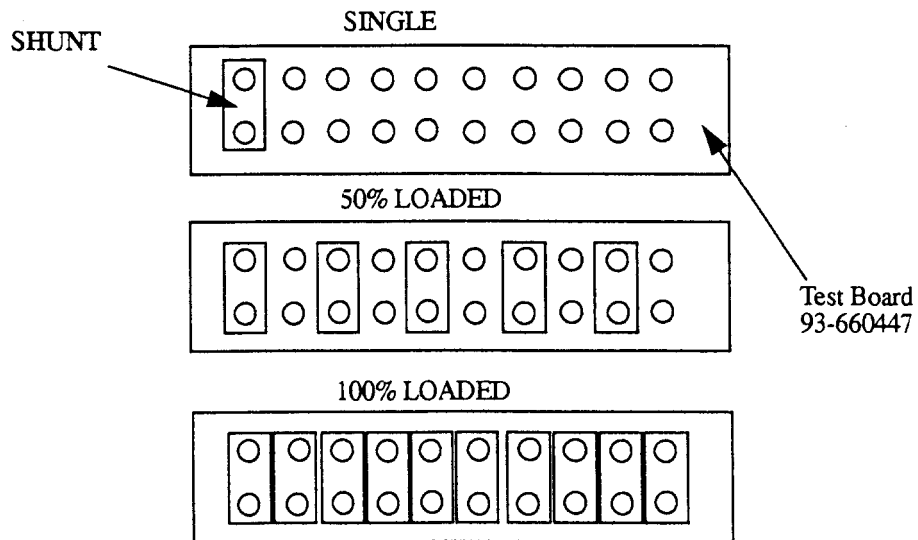

Figure 5A
Temperature Rise Vs Current Loading Configurations

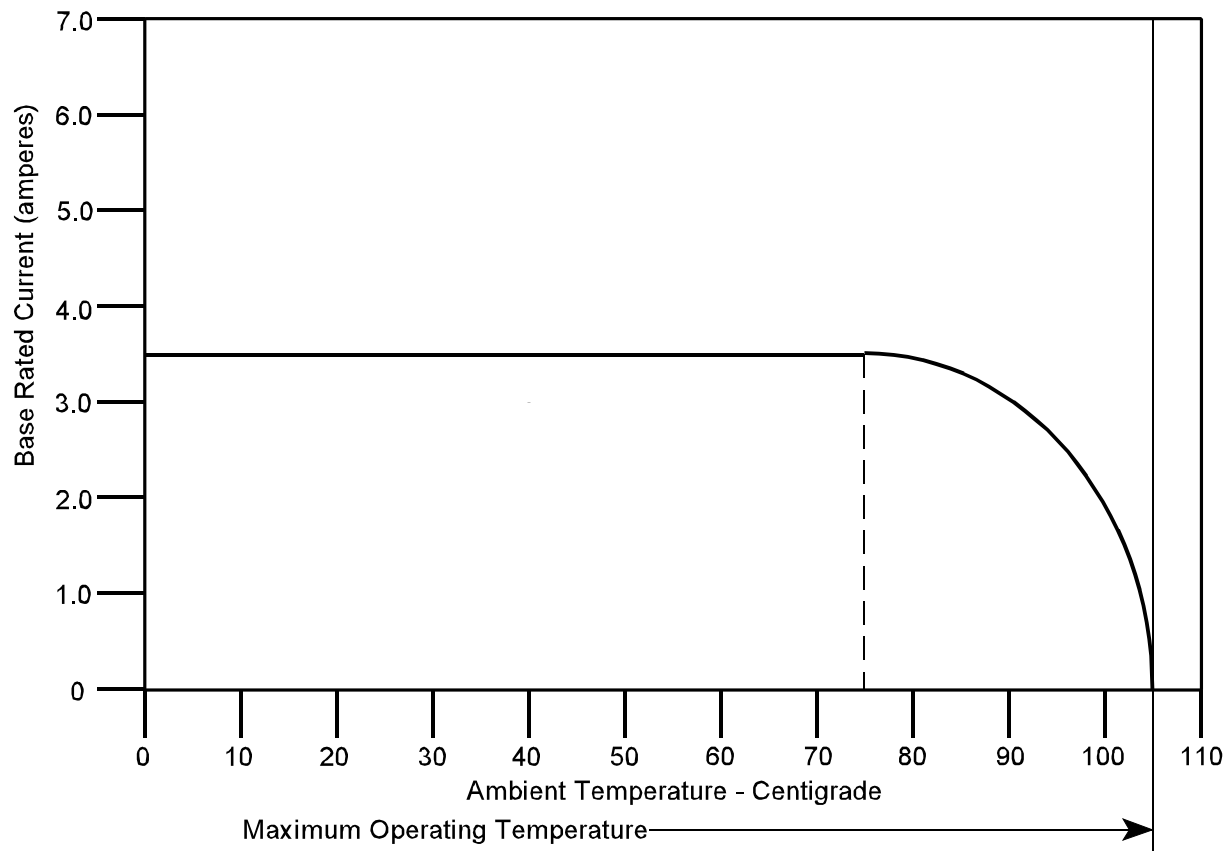

Figure 5B
Current Carrying Capability

Percent Connector Loading	Current Rating (amperes)
Single Contact	3.46
50	2.97
100	2.40

Figure 5C
Current Rating

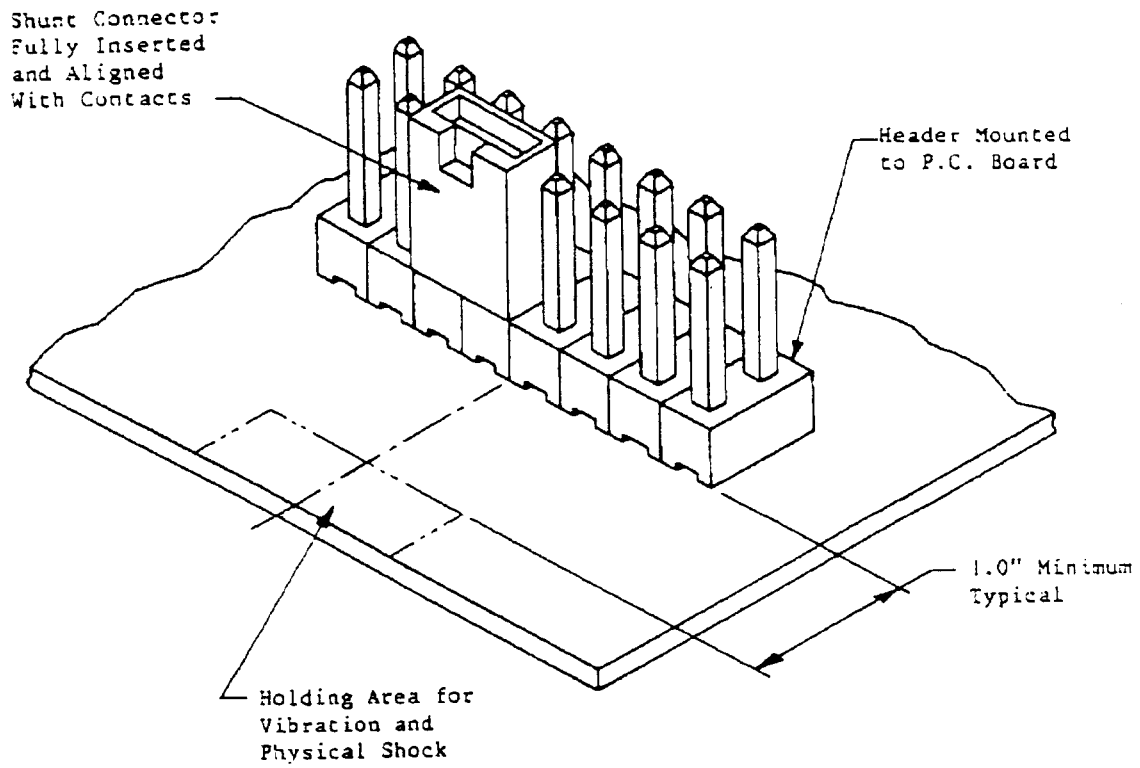

Figure 6
Vibration & Physical Shock Mounting Fixture