

NOTE



All numerical values are in metric units [with U.S. customary units in brackets]. Dimensions are in millimeters [and inches]. Unless otherwise specified, dimensions have a tolerance of ± 0.13 [$\pm .005$] and angles have a tolerance of $\pm 2^\circ$. Figures and illustrations are for identification only and are not drawn to scale.

1. INTRODUCTION

This specification covers the requirements for application of LED Star Board Holder for use in direct lighting applications (such as office, automotive, communications, and architectural). The star board holder is designed to house and provide electrical interconnection and thermal solution for a high-power LED star printed circuit (pc) board light source. The star board holder consists of a heat sink, locking ring, and contact carrier assembly, and is available with or without a diffuser lens. Snap-on adapters for commercial fiber optic lenses and light guides are available separately.

The star board holder is capable of two-contact loading for single-color LEDs and three- or four-contact loading for full-color (RGB) LEDs (common anode or common cathode). The contact carrier assembly and heat sink are marked with A, B, C, and D to reference the polarity of the LED to ensure proper orientation in the lighting fixture. Soldering or thermally conductive adhesive is not required for assembly. These star board holders are designed to be used with an Underwriters Laboratories Inc. (UL) Class 2 power supply.

When corresponding with personnel, use the terminology provided in this specification to facilitate your inquiries for information. Basic terms and features of this product are provided in Figure 1.

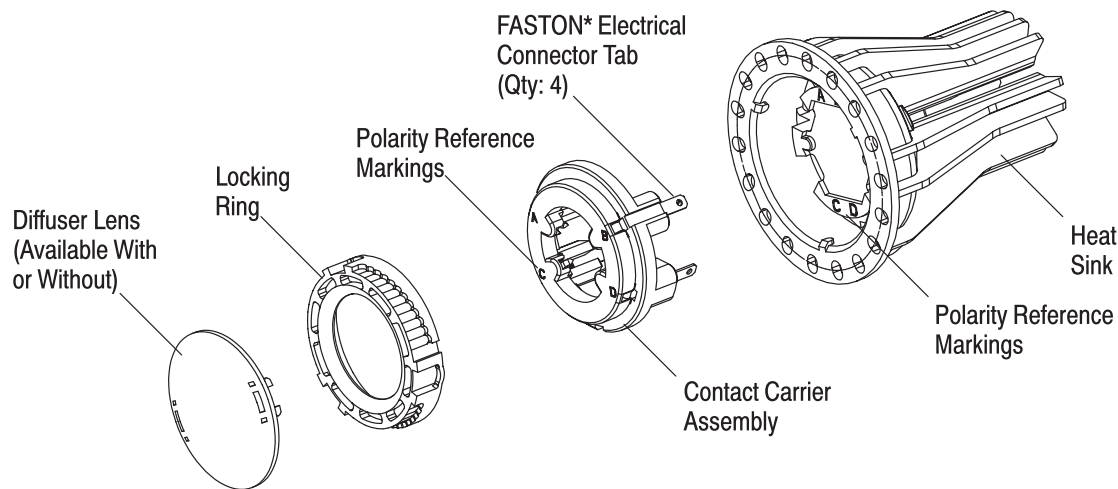

Figure 1

2. REFERENCE MATERIAL

2.1. Revision Summary

- Initial release of application specification

2.2. Customer Assistance

Reference Product Base Part Number 2008675 and Product Code L012 are representative of LED Star Board Holder. Use of these numbers will identify the product line and expedite your inquiries through a service network established to help you obtain product and tooling information. Such information can be obtained through a local Representative or, after purchase, by calling PRODUCT INFORMATION at the number at the bottom of page 1.

2.3. Drawings

Customer Drawings for product part numbers are available from the service network. If there is a conflict between the information contained in the Customer Drawings and this specification or with any other technical documentation supplied, call PRODUCT INFORMATION at the number at the bottom of page 1.

2.4. Specifications

Product Specification 108-2350 provides product performance and test information.

2.5. Instructional Material

Instruction Sheets (408-series) provide product assembly instructions or tooling setup and operation procedures. There are no documents available that pertain to this product.

3. REQUIREMENTS

3.1. Material

The contact carrier assembly and locking ring are made of polybutylene terephthalate (PBT). The contacts are made of copper alloy plated with tin. The heat sink is made of cast aluminum. The lens (if included) is made of polycarbonate.

3.2. Safety

Do not stack product shipping containers so high that the containers buckle or deform.

3.3. Limitations

The star board holder is designed to operate in a temperature range of -40° to 85°C [-40° to 185°F].

3.4. Storage

A. Shelf Life

The star board holder should remain in the shipping containers until ready for use to prevent deformation to the contacts. The assemblies should be used on a first in, first out basis to avoid storage contamination that could adversely affect performance.

B. Chemical Exposure

Do not store the star board holder near any chemical listed below as they may cause stress corrosion cracking in the contacts.

| | | | | | |
|----------|------------|----------|------------|----------|------------------|
| Alkalies | Ammonia | Citrates | Phosphates | Citrates | Sulfur Compounds |
| Amines | Carbonates | Nitrites | Sulfur | Nitrites | Tartrates |

3.5. Thermal Performance

The thermal performance of the overall system is paramount to the life of the LED. The star board holder supports 1 to 3 watts of input to the LED without using forced air cooling or additional heat sink. IT IS IMPORTANT that the thermal management is adequate for the specific LED and lighting fixture used. LEDs with higher wattage rating can be used if forced air cooling or additional heat sink is employed.

3.6. Customer Supplied Components

A. LED

The star board holder is compatible with hexagonal "star board" high-power LEDs measuring 19.9 [.783] across the hexagonal flats and having a thickness of 1 to 2.5 [.040 to .01]. A sample reference star board pattern is given in Figure 2.

Sample "Star Board" Pattern

Figure 2

B. Connections

The electrical connector tabs of the star board holder accept Ultra-Fast Series 110 fully-insulated FASTON receptacles.

3.7. Assembly

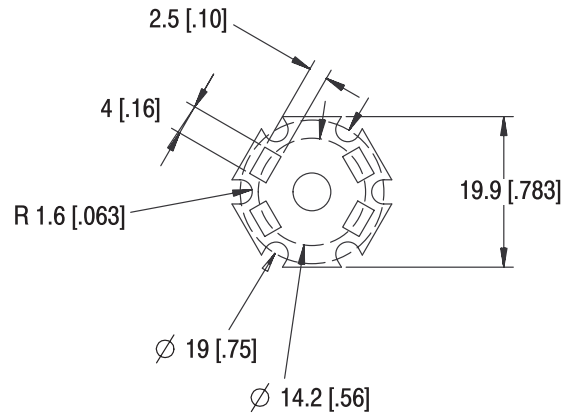
The star board holder must be assembled using the following requirements:

1. A thermally-conductive pad or thermal grease must be placed into the hexagonal inset of the heat sink.
2. The LED must be installed over the thermally-conductive pad or thermal grease. The polarity of the LED should be oriented with the polarity reference markings of the heat sink.
3. The contact carrier assembly must be inserted into the heat sink with the polarity reference markings aligned (A with A, B with B, C with C, and D with D).
4. The locking ring must be inserted into the heat sink and rotated using a long-nosed pliers or large snap ring tool with right-angle tips so that it secures the contact carrier assembly.
5. If used, the diffuser lens and other optional components must be installed onto the locking ring.
6. The wire assemblies must be connected to the electrical connector tabs.

Refer to Figure 3.

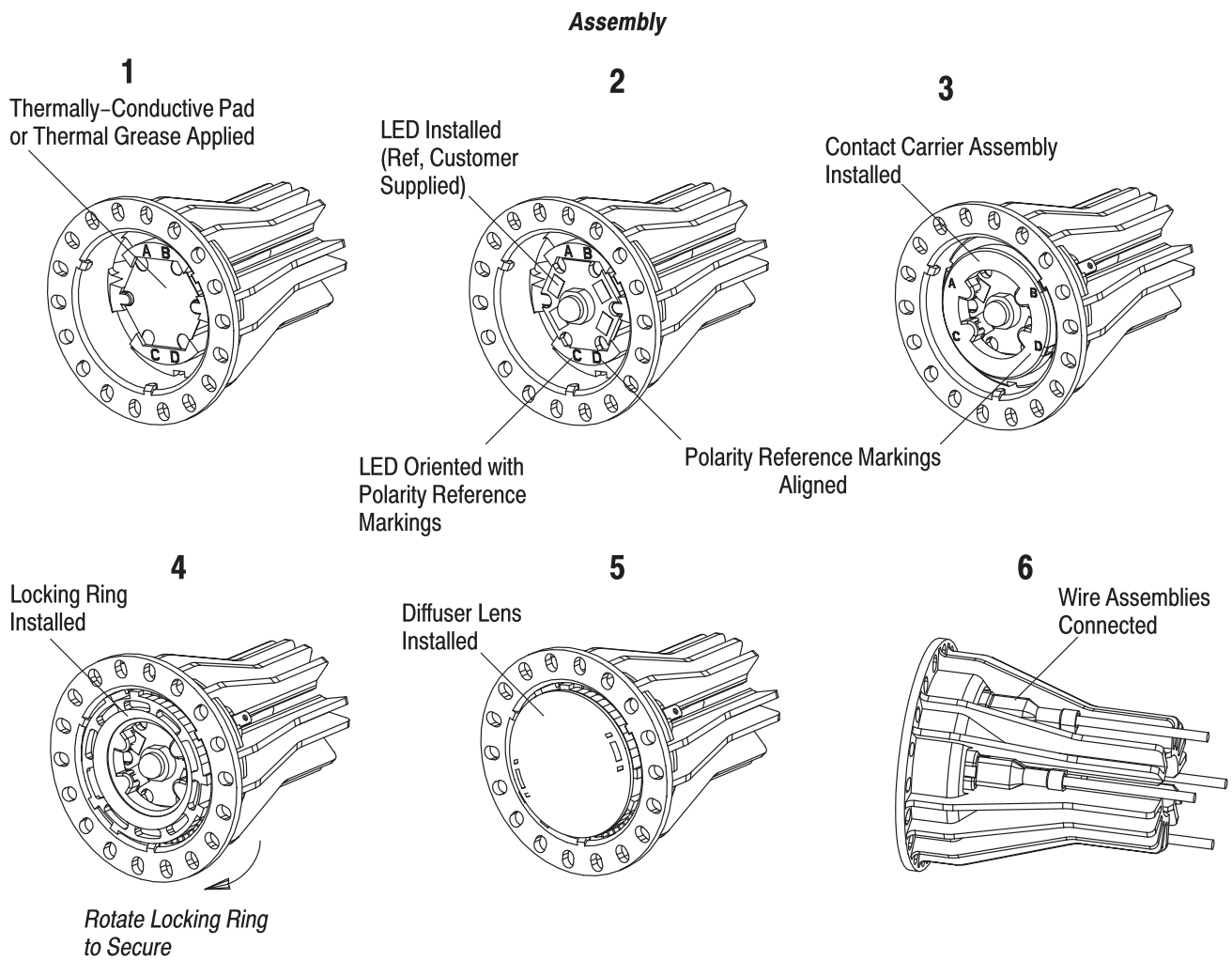

Figure 3

3.8. Replacement and Repair

The star board holder is not repairable. Damaged or defective components **MUST NOT** be used.

4. QUALIFICATION

No qualifying support for LED Star Board Holder was defined at the time of publication of this document.

5. TOOLING

A long-nosed pliers or a large snap ring tool with right-angle tips to install the locking ring.

6. VISUAL AID

The illustration below shows a typical application of LED Star Board Holder. This illustration should be used by production personnel to ensure a correctly applied product. Applications which DO NOT appear correct should be inspected using the information in the preceding pages of this specification and in the instructional material shipped with the product or tooling.

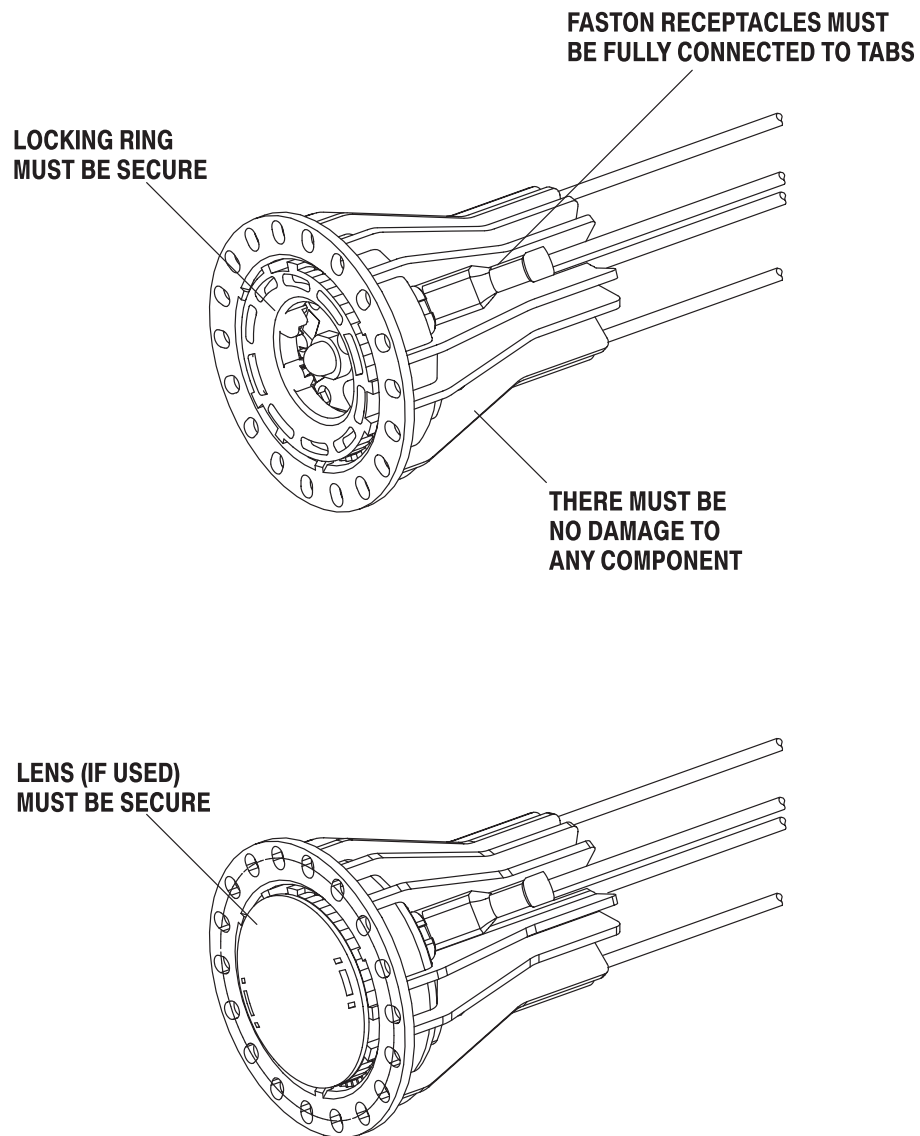

FIGURE 4. VISUAL AID