

### Figure

- Ratings 5A
- Coil-Contacts 4,000VAC

### Contact Data @ 23°C

Contact Arrangements: 1a (1FormA), 1c (1FormC)  
 Contact Material: AgSnO<sub>2</sub>  
 Max. Switching Rate: 300 ops./min. (no load)  
 20 ops./min. (rated load)  
 Expected Mechanical Life: 10,000,000 ops. (no load)  
 Expected Electrical Life: 100,000 ops. (rated load)  
 Min. Contact Load : 100mA,5VDC (reference data)  
 Initial Contact Resistance : 100milliohms @ 1A ,6VDC

### Contact Ratings

Ratings :

1a,400mW	5A 277VAC (resistive load)
	5A 30VDC (resistive load)
	10A 125VDC (resistive load)
	TV-3 (NO contact)
1c,400mW	5A(NO contact),3A(NC contact) 277VAC(resistive load)
	5A(NO contact),3A(NC contact) 30VDC(resistive load)
	TV-3 (NO contact)
1a,200mW	5A 277VAC (resistive load)
	5A 30VDC (resistive load)
	10A 125VAC (resistive load)

Max. Switching Voltage : 277VAC,30VDC  
 Max. Switching Current : 10A(NO contact),3A(NC contact)  
 Max. Switching Power : 1,385VA(AC), 150W(DC)(NO contact)  
 831VA(AC), 90W(DC)(NC contact)

### Initial Dielectric Strength

Between Open Contacts : 750VAC 50/60Hz (1min.)  
 Between Coil and Contacts : 4,000VAC 50/60Hz(1min.)  
 Surge Voltage Between Coil and Contacts : 8,000V(1.2/50μs)

### Initial Contact Resistance





Between Mutually Insulated Conductors : 1,000 milliohms @ 500VDC

# PCH series

## 5Amp Compact And High Capacity

PC Board Mount, Cd-free, Pb-free, RoHS Compliant

Air Conditioners, Refrigerators, Microwave Ovens

	File No. E82292
	File No. LR48471(400mW standard type)
	Reg.-Nr. 119568
	File No. 08001023449

Users should thoroughly review the technical data before selecting a product part number. It is recommended that user also seek out the pertinent approvals files of the agencies/laboratories and review them to ensure the product meets the requirements for a given application.

### Coil Data @ 23°C

Rated Voltage : 5-48\*VDC (\* Not prepared 48Vdc / 200mW type)  
 Rated Power : 400mW(standard type),  
 200mW(High Sensitive Type)  
 Limiting Voltage: 130% of nominal.

#### Coil Data @23°C

400mW(Standard type)				
Rated Coil Voltage (VDC)	Rated Current (mA)	Coil Resistance (ohms)±10%	Operate Voltage (VDC)	Release Voltage (VDC)
5	80.0	62.5	3.75	0.25
6	66.7	90.0	4.50	0.30
9	44.4	202.5	6.75	0.45
12	33.3	360	9.0	0.6
18	22.2	810	13.5	0.9
24	11.1	1440	18.0	1.2
48	5.6	5760	36.0	2.4

#### Coil Data @23°C

200mW(High Sensitive Type)*				
Rated Coil Voltage (VDC)	Rated Current (mA)	Coil Resistance (ohms)±10%	Operate Voltage (VDC)	Release Voltage (VDC)
5	40.0	125	3.75	0.25
6	30.0	180	4.50	0.30
9	22.5	400	6.75	0.45
12	16.7	720	9.0	0.6
24	8.6	2880	18.0	1.2

\*Not prepared 1 Form C / 200mW type

### Operate Data

Operate Voltage : 75% of nominal voltage or less  
 Release Voltage : 5% of nominal voltage or more  
 Operate Time : 10ms max  
 Release Time : 5ms max

### Environmental Data

Temperature Range : -4°C~  
 (on conditions without freezing and dew condensation)

Vibration, Mechanical : 10~55Hz. 1.5mm double amplitude  
 Operational : 10~55Hz. 1.5mm double amplitude

Shock, Mechanical : 980m/s<sup>2</sup> (Half -Sine wave of 6ms)

Operational : 98m/s<sup>2</sup>

(Half -Sine wave of 11ms, permitted duration 1ms)

Operating Humidity : 20~85%RH (Non-condensing)

### Mechanical Data

Termination : PC board terminals

Enclosure : blank ; Flux Proof

H ; Wash Tight

Weight : Approx. 7g

## Ordering Information for Relays

**Example Part No.** PCH -1 12 D 2 M H ,000

1. Basic Series	PCH = Compact PCB mount type						
2. Poles	1 = 1pole						
3. Coil Voltage	05 = 5VDC	12 = 12VDC					
	06 = 6VDC	24 = 24VDC					
	09 = 9VDC	48 = 48VDC*					
4. Coil Power	D = 400mW (1a,1c)						
	L = 200mW (1a)						
5. Contact Material	2 = AgSnO <sub>2</sub>						
6. Contact Arrangement	blank = 1c						
	M = 1a						
7. Enclosure	blank = Flux Proof						
	H = Wash Tight						
8. Suffix	,000 = Standard model						
	Other						
	Suffix = Custom model						

\*Coil voltage: 48VDC only can chose 400mW type.

### Outline Dimensions (mm)

1c\*

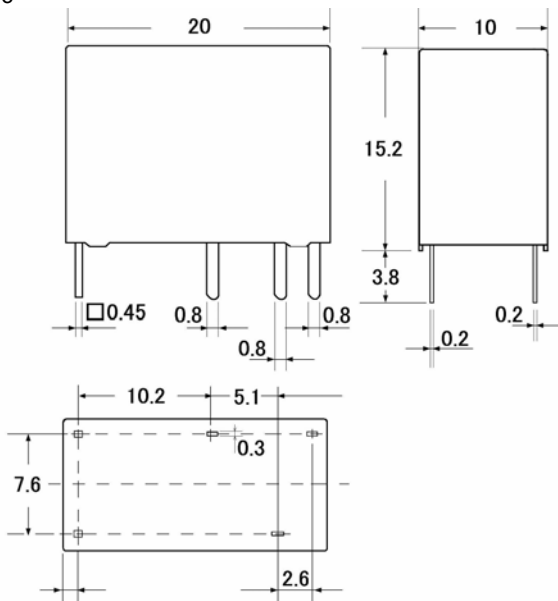

\*1a Outline dimensions is omitted.

Tolerance: 0.99mm Max.: +/-0.1mm, 1-2.99mm: +/-0.2mm, 3mm Min.: +/-0.3mm

### Wiring Diagram (Bottom View)

1c

1a

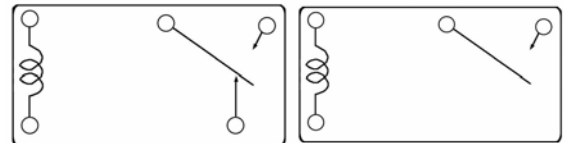

### PC Board Layout (mm) (Bottom View)

1c

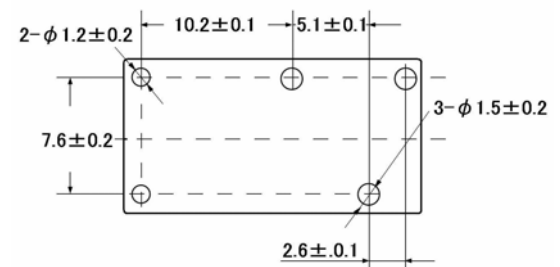

1a

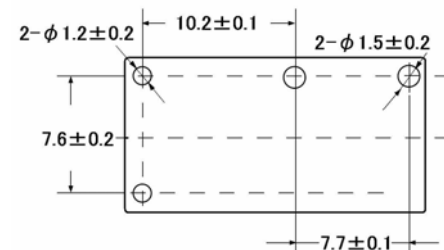

Reference Data

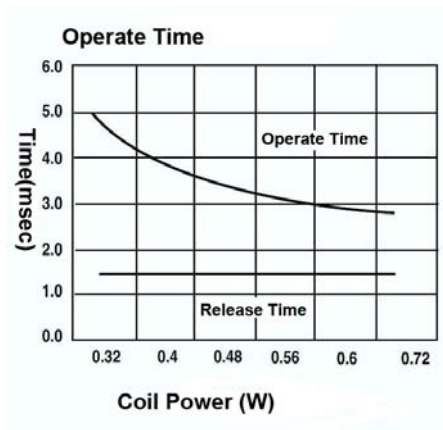
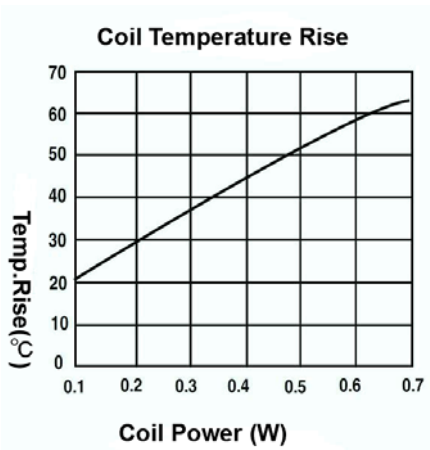

\*Above reference data is apply for 1 Form C / NO contact side, rated voltage: 277Vac / Coil power: 400mW.  
 \*Please contact with us about the graph of expected electrical life.