

Power Relay K-S



**Features**

- High current design: limiting continuous current 50 A at 85°C
- Very low voltage drop
- Wide voltage range

**Typical Applications**

- ABS control
- Blower fans
- Cooling fan
- Engine control
- Glow plug
- Heated rear screen
- Ignition
- Main switch/supply relay
- Preheating system
- Valves
- Wiper control

Please contact Tyco Electronics for relay application support.



071S\_3d\_3

**Design**

- ELV/RoHS/WEEE compliant
- Open: flux tight type

**Weight**

Approx. 19 g (0.68 oz.)

**Nominal Voltage**

12 V or 24 V; other nominal voltages available on request

**Terminals**

PCB terminals for assembly on printed circuit boards

**Conditions**

All parametric, environmental and endurance tests are performed according to EIA Standard RS-407-A at standard test conditions unless otherwise noted:  
23°C ambient temperature,  
20 - 50% RH, 998.9 ±33.9 hPa.

For general storage and processing recommendations please refer to our Application Notes and especially to *Storage* in the "Glossary" page 23 or at <http://relays.tycoelectronics.com/appnotes/>

**Disclaimer**

All technical performance data apply to the relay as such, specific conditions of the individual application are not considered. Please always check the suitability of the relay for your intended purpose. We do not assume any responsibility or liability for not complying herewith. We recommend to complete our questionnaire and to request our technical service. Any responsibility for the application of the product remains with the customer only. All specifications are subject to change without notification. All rights of Tyco Electronics are reserved.

Power Relay K-S

**Dimensional Drawing**

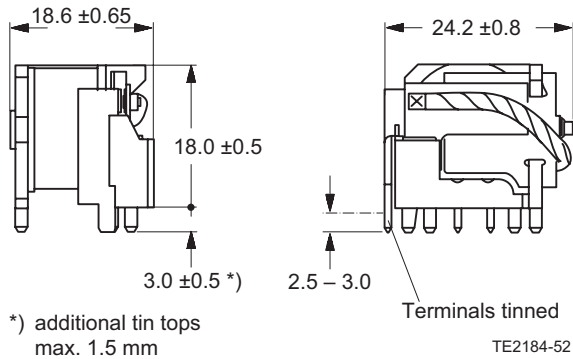

**Mounting Hole Layout (bottom view)**

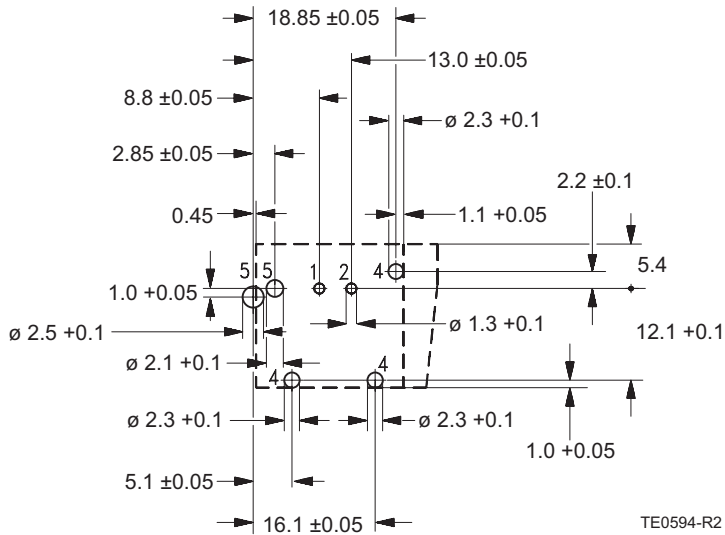

**Power Relay K-S**

Contact Data		
Contact configuration	1 Make contact/ 1 Form A	
Circuit symbol (see also Pin assignment)		
Rated voltage	12 V	24 V
Rated current	50 A	
Limiting continuous current		
23°C	70 A	
85°C	50 A	
Contact material	AgNi0.15	
Max. switching power	See load limit curve	
Max. switching current <sup>1)</sup>		
On <sup>2)</sup>	300 A	150 A
Off	70 A	35 A
Min. recommended load <sup>3)</sup>	1 A at 5 V	
Voltage drop at 10 A (initial)	Typ. 10 mV, 300 mV max.	
Mechanical endurance (without load)	> 10 <sup>6</sup> operations	
Electrical endurance (example of resistive load)	> 5 x 10 <sup>4</sup> operations at 13.5 V/50 A	> 1 x 10 <sup>5</sup> operations at 27.5 V/15 A

<sup>1)</sup> The values apply to a resistive or inductive load with suitable spark suppression and at maximum 13.5 V for 12 V or 27 V for 24 V load voltages.

<sup>2)</sup> For a load current duration of maximum 3 s for a make/break ratio of 1:10.

<sup>3)</sup> See chapter Diagnostics of Relays in our Application Notes page 31 or consult the internet at <http://relays.tycoelectronics.com/appnotes/>

**Load Limit Curve**

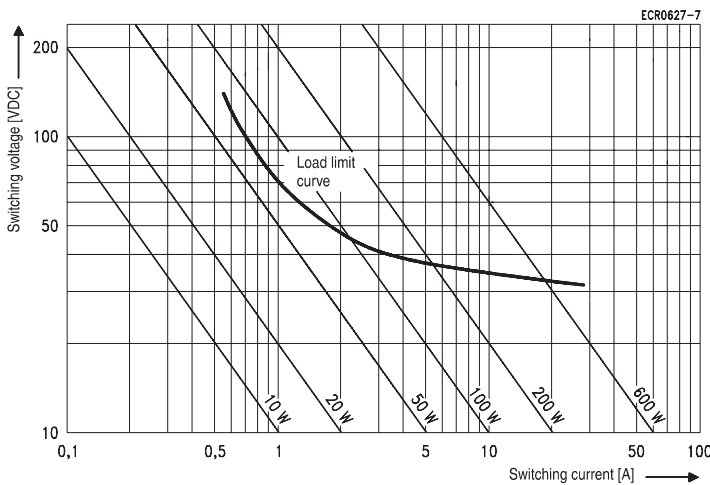

Load limit curve  $\hat{=}$  safe shutdown,  
no stationary arc

**Circuit Diagram**

1 Make contact/1 Form A

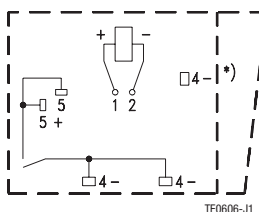

Note:  
Check polarity and frame connection (ground)

\* For mounting only, not for electrical connection.

**Power Relay K-S**

**Coil Data**

Available for nominal voltages	12 V / 24 V
Nominal power consumption of the unsuppressed coil at nominal voltage	2.25 W
Test voltage winding/contact	500 VAC <sub>rms</sub>
Maximum ambient temperature range <sup>1)</sup>	-40 to +85°C
Operate time at nominal voltage	Typ. 4 ms
Release time at nominal voltage <sup>2)</sup>	Typ. 3 ms

<sup>1)</sup> See also operating voltage range diagram.

<sup>2)</sup> For unsuppressed relay coil.

**Note:**

A low resistive suppression device in parallel to the relay coil increases the release time and reduces the lifetime caused by increased erosion and/or higher risk of contact tack welding.

**Operating Voltage Range**

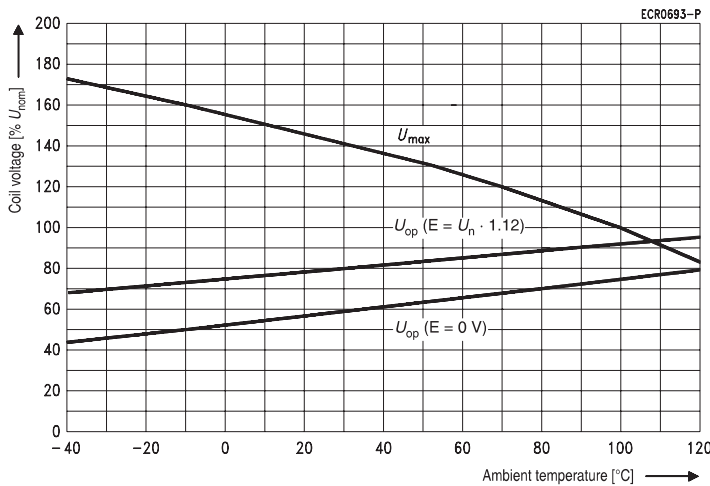

Does not take into account the temperature rise due to the contact current  
E = pre-energization

**Environmental Conditions**

Temperature range, storage	Refer to <i>Storage</i> in the "Glossary" catalog page 23 or <a href="http://relays.tycoelectronics.com/appnotes/">http://relays.tycoelectronics.com/appnotes/</a>			
Test	Relevant standard	Testing as per	Dimension	Comments
Vibration resistance	IEC 68-2-6 (sine pulse form) acceleration, acc. to position		10 - 200 Hz 20 - 40 g	No change in the switching state > 10 μs
Shock resistance	IEC 68-2-27 (half sine form single pulses) acceleration		8 ms 30 g	
Solderability	IEC 68-2-20	Ta, Method 1	Hot dip 5 s 215°C	Aging 3 (4 h/155°C) for leaded process (T <sub>m</sub> = 183°C) for Pb-free process (T <sub>m</sub> = 217°C)
Resistance to soldering heat	IEC 68-2-20	Tb, Method 1A	Hot dip 10 s 260°C	with thermal screen

Power Relay K-S

Ordering Information

Part Numbers (see table below for coil data)		Contact Arrangement	Contact Material	Enclosure	Terminals
Relay Description	Part Number				
V23071-A1009-A132	1393276-3	1 Form A (make contact)	AgNi0.15	Open	Printed circuit
V23071-A1010-A132	1393276-7	1 Form A (make contact)	AgNi0.15	Open	Printed circuit

Coil Versions

Coil Data for Power K-S	Rated Coil Voltage (V)	Coil Resistance $\pm 10\%$ ( $\Omega$ )	Must Operate Voltage (V)	Must Release Voltage (V)	Allowable Overdrive <sup>1)</sup> Voltage (V)	
					at 23°C	at 85°C
V23071-**-009-***	12	64	6.9	1.2	18.5	14.5
V23071-**-010-***	24	234	14.1	2.4	31.1	24.7

<sup>1)</sup> Allowable overdrive is stated with no load applied and minimum coil resistance.

**Standard Delivery Packs** (orders in multiples of delivery pack)

Power K-S: 400 pieces