

## Double Nano Relay (THT – THR)



### Features

- Smallest automotive PCB relay in its class:
  - Minimum PCB area required: 157 mm<sup>2</sup>
  - Dimensions: L x H x W (mm)  
15.4 x 14.0 x 10.2
  - Minimal height: 14.0 mm
  - Minimal weight
- First automotive relay using overmolding technology
- Highest reliability due to overmolding process
- Limiting continuous current 30 A
- Very easy routing of PCB-layout
- Power-saving high-impedance coil
- Low noise operation
- Wave (THT) and reflow (THR/pin-in-paste) solderable versions
- For single version refer to Single Nano Relay

### Typical Applications

- Car alarm
- Door control
- Door lock
- Electrical steering column lock
- Heated rear screen
- Immobilizer
- Seat control
- Sun roof
- Window lifter

Please contact Tyco Electronics for relay application support.



138\_3D03

### Design

- ELV/RoHS/WEEE compliant
- THT: sealed type washable
- THR: sealed type open vent hole

### Weight

Approx. 6.5 g (0.23 oz.)

### Nominal Voltage

12 V

### Terminals

PCB terminals for assembly on printed circuit boards

### Conditions

All parametric, environmental and endurance tests are performed according to EIA Standard RS-407-A at standard test conditions unless otherwise noted:  
23°C ambient temperature,  
20 - 50% RH, 998.9 ±33.9 hPa.

For general storage and processing recommendations please refer to our Application Notes and especially to *Storage* in the “Glossary” page 23 or at <http://relays.tycoelectronics.com/appnotes/>

### Disclaimer

All technical performance data apply to the relay as such, specific conditions of the individual application are not considered. Please always check the suitability of the relay for your intended purpose. We do not assume any responsibility or liability for not complying herewith. We recommend to complete our questionnaire and to request our technical service. Any responsibility for the application of the product remains with the customer only. All specifications are subject to change without notification. All rights of Tyco Electronics are reserved.

**Double Nano Relay (THT – THR)**

**Dimensional Drawing**

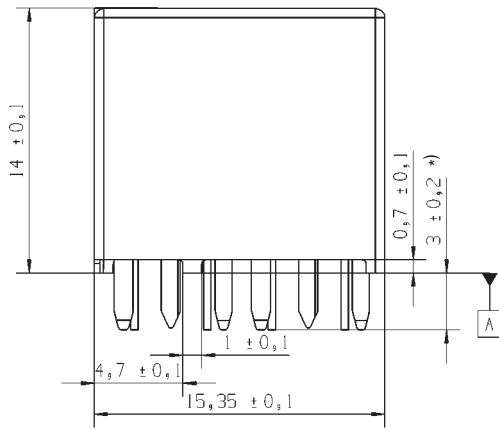

138\_DD3

\*) Additional tin tops max. 1 mm

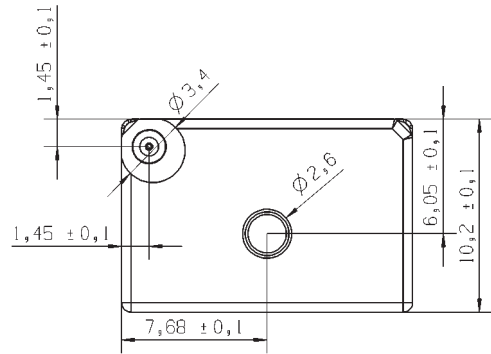

Tolerances unless otherwise specified + / - 0.2

138\_DD3

**View of the Terminals (bottom view)**

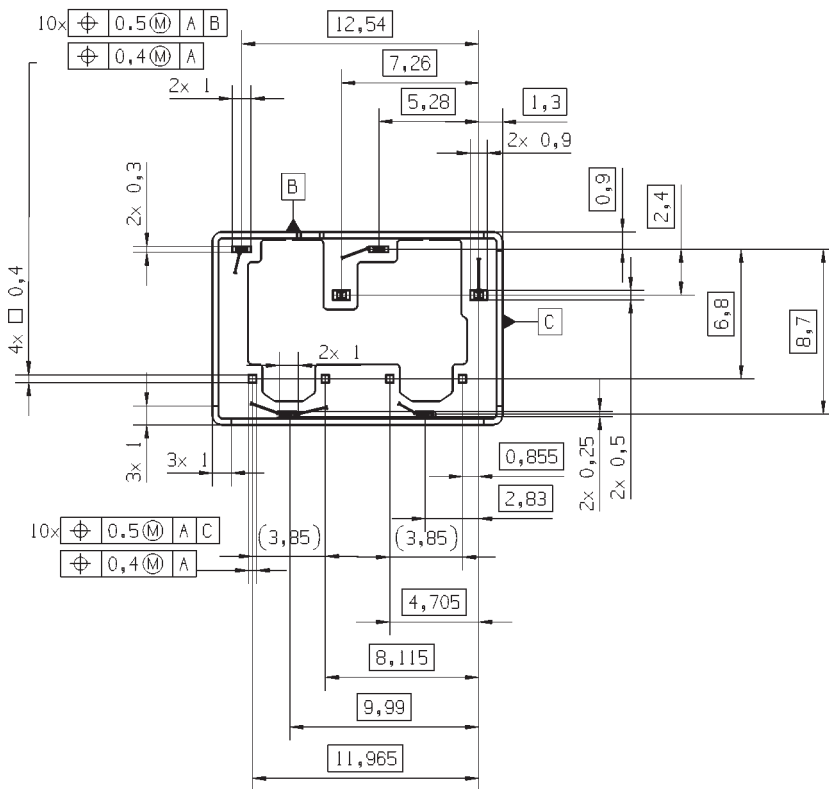

138\_VT3

**Double Nano Relay (THT – THR)**

Contact Data			
Typical areas of application	Resistive/inductive load		
Contact configuration	2 Changeover contacts/ 2 Form C		
Circuit symbol (see also Pin assignment)			
Rated voltage	12 V		
Rated current	NC/NO 15 A/20 A		
Limiting continuous current	Single excitation	H-bridge configuration	
	NC/NO		
	23°C	25 A/30 A	25 A
	85°C	15 A/20 A	15 A
105°C	10 A/10 A	10 A	
Contact material	Silver based		
Max. switching voltage/power	See load limit curve		
Max. switching current <sup>1)</sup>	NC/NO		
On <sup>2)</sup>	30 A		
Off	30 A		
Min. recommended load <sup>3)</sup>	1 A at 5 V		
Voltage drop at 10 A (initial) for NC/NO contacts	Typ. 30 mV, 300 mV max.		
Mechanical endurance (without load)	> 5 x 10 <sup>6</sup> operations		
Electrical endurance at cyclic temperature -40/+23/+85°C and 13.5 V	Motor reverse blocked: > 10 <sup>5</sup> operations at 25 A, 0.77 mH inductive load		

- <sup>1)</sup> The values apply to a resistive or inductive load with suitable spark suppression and at maximum 13.5 V for 12 V load voltages.
- <sup>2)</sup> For a load current duration of maximum 3 s for a make/break ratio of 1:10.
- <sup>3)</sup> See chapter Diagnostics of Relays in our Application Notes page 31 or consult the internet at <http://relays.tycoelectronics.com/appnotes/>

**Load Limit Curve**

138S\_LLC1

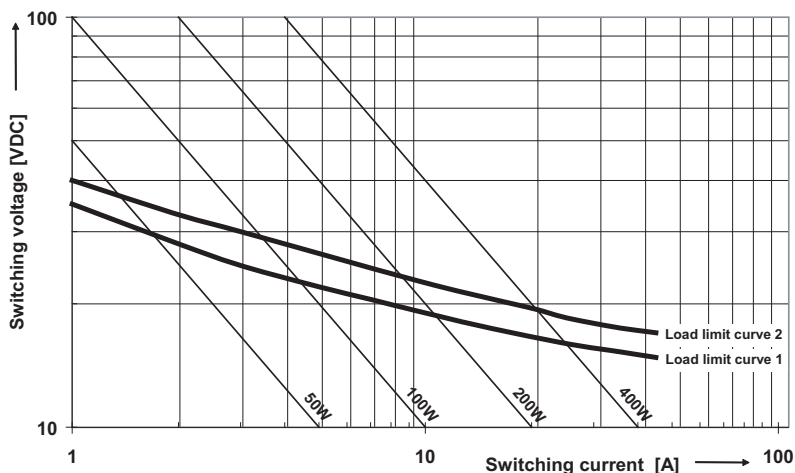

Load limit curve 1 ≙ arc extinguishes during transit time  
Load limit curve 2 ≙ safe shutdown, no stationary arc

**Double Nano Relay (THT – THR)**

**Circuit Diagram**

2 Changeover contacts/2 Form C

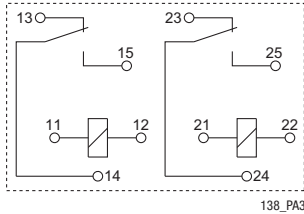

**Coil Data**

Available for nominal voltages	12 V
Nominal power consumption of the unsuppressed coil at nominal voltage	0.8 W
Test voltage winding/contact	500 VAC <sub>rms</sub>
Maximum ambient temperature range <sup>1)</sup>	-40 to +105°C
Operate time at nominal voltage	Typ. 3 ms
Release time at nominal voltage <sup>2)</sup>	Typ. 1.5 ms

<sup>1)</sup> Permanent use above 85°C could be critical.

<sup>2)</sup> For unsuppressed relay coil.

**Note:**

A low resistive suppression device in parallel to the relay coil increases the release time and reduces the lifetime caused by increased erosion and/or higher risk of contact tack welding.

**Operating Voltage Range**

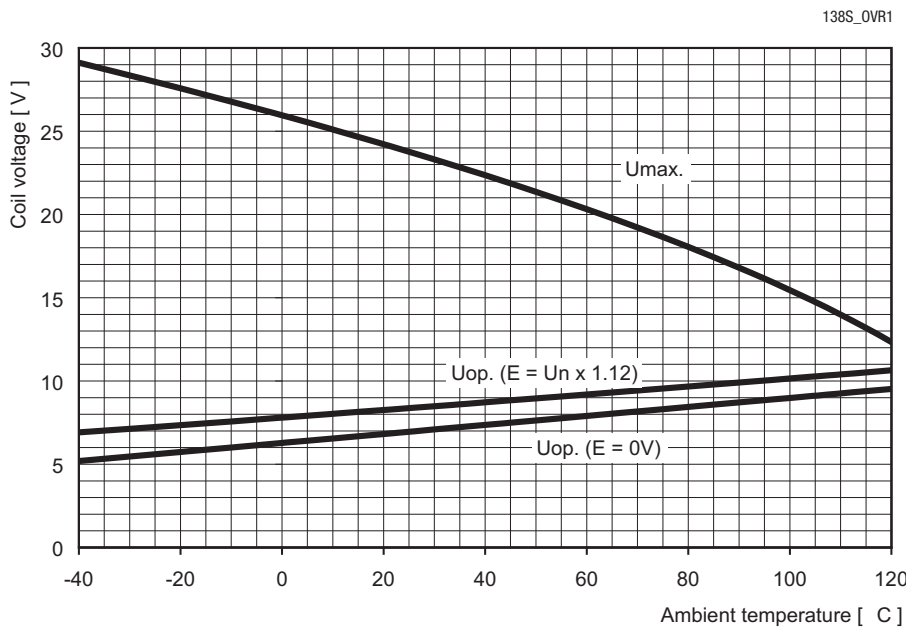

Does not take into account the temperature rise due to the contact current  
E = pre-energization

**Double Nano Relay (THT – THR)**

<b>Environmental Conditions</b>					
Temperature range, storage		Refer to <i>Storage</i> in the “Glossary” catalog page 23 or <a href="http://relays.tycoelectronics.com/appnotes/">http://relays.tycoelectronics.com/appnotes/</a>			
Test		Relevant standard	Testing as per	Dimension	Comments
Cold storage		IEC 68-2-1		1000 h	-40°C
Dry heat		IEC 68-2-2	Ba	1000 h	125°C
Climatic cycling with condensation					
	THT	EN ISO 6988		20 cycles	Storage 8/16 h
Thermal change		IEC 68-2-14	Nb	35 cycles	-40/+125°C
Thermal shock		IEC 68-2-14	Na	1000 cycles	-40/+125°C Dwell time 1 h
Damp heat					
	THT	IEC 68-2-30	Db, Variant 2	6 cycles	25°C/55°C/93%
	THT	IEC 68-2-3	Method Ca	56 days	40°C/93%
Corrosive gas		IEC 68-2-42 IEC 68-2-43		10 days 10 days	
Vibration resistance		IEC 68-2-6 (sine pulse form)		10 - 500 Hz 6 g	No change in the switching state > 10 µs
Shock resistance		IEC 68-2-27 (half sine form single pulses)		6 ms up to 30 g	No change in the switching state > 10 µs
Solderability				Hot dip 5 s	Aging 3 (4 h/155°C)
	THT	IEC 68-2-20	Ta, Method 1	215°C	for leaded process (T <sub>m</sub> = 183°C)
	THR	IEC 68-2-58		245°C	for Pb-free process (T <sub>m</sub> = 217°C)
Resistance to soldering heat				Hot dip 10 s	with thermal screen
	THT	IEC 68-2-20	Ta, Method 1A	260°C	
	THR	IEC 68-2-58		260°C	Preheating min 130°C
Sealing					
	THT	IEC 68-2-17	Qc, Method 2		1 min/70°C
	THR				Open vent hole

**Ordering Information**

<b>Part Numbers</b> (see table below for coil data)		<b>Contact Arrangement</b>	<b>Contact Material</b>	<b>Enclosure</b>	<b>Soldering Technology</b>
<b>Relay Description</b>	<b>Part Number</b>				
V23138-C2005-A403	8-1414964-8	2 Form C	Silver based	Sealed	THT
V23138-R2005-A403	1-1414960-2	2 Form C	Silver based	Open vent hole	THR

**Coil Versions**

<b>Coil Data for Nano</b>	<b>Rated Coil Voltage (V)</b>	<b>Coil Resistance ±10% (Ω)</b>	<b>Must Operate Voltage (V)</b>	<b>Must Release Voltage (V)</b>	<b>Allowable Overdrive<sup>1)</sup> Voltage (V)</b>	
					<b>at 23°C</b>	<b>at 105°C</b>
V23138-**005-****	12	180	6.9	1.0	24	14.7

<sup>1)</sup> Allowable overdrive is stated with no load applied and minimum coil resistance.

**Standard Delivery Packs** (orders in multiples of delivery pack)

Nano – THT/THR: 1360 pieces