

Alphanumeric Index

Series	Type	Page
T72M	Single 20A Relay	1005
V23086	Single or Dual 20A Relay	1002
V2R	20A Motor Reversing Module	1012
VF4	40A Relay	1017
VF7	70A Relay	1021
VFM	20A Relay	1014
VKP	40A Relay	1007
VTF	Flasher Module	1024

Automotive Relay Question Tree

This guide helps the user select one or more relay series which may be appropriate for a given application. The user should then refer to detailed specifications elsewhere in this catalog to determine the actual part number to be specified. Of course, the user must assume ultimate responsibility for determining the suitability of a relay for a particular application.

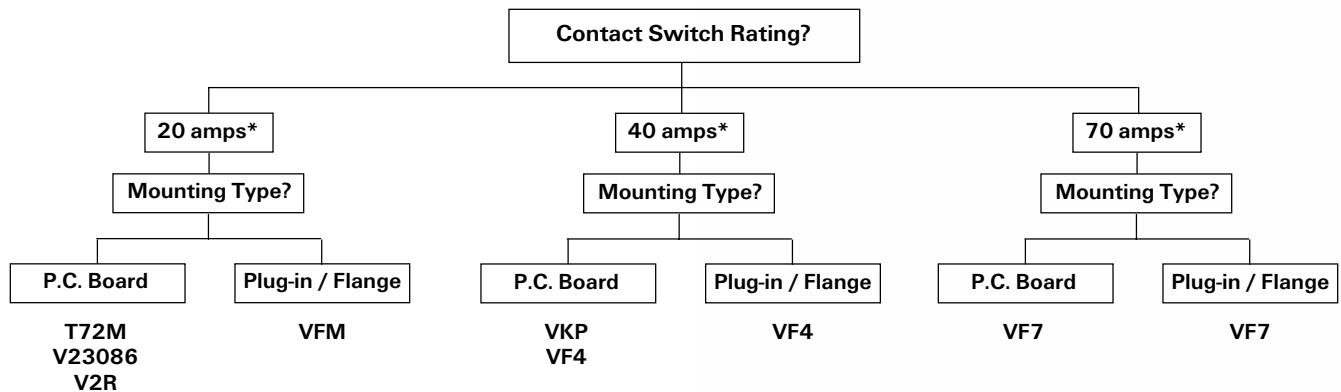

* Typical loads at 14VDC, resistive, for comparison purposes. See catalog pages for a given series for detailed rating specifications.

NOTE: The "automotive" relays described in this section are DC coil relays designed to switch 14VDC loads in automobiles. They may also be suitable for non-automotive applications such as electric wheelchairs and other battery powered equipment. They are not UL recognized.



V23086 series

20 Amp Micro K (Single & Dual) PC Board Relay for Automotive Applications

Users should thoroughly review the technical data before selecting a product part number. It is recommended that users also seek out the pertinent approvals files of the agencies/laboratories and review them to ensure the product meets the requirements for a given application.

Features

- 30A, 16VDC switching rating.
- 40A inrush at 16VDC.
- 20A continuous contact rating @ 85°C.
- Immersion cleanable plastic case with knock-off nib for ventilation.
- 60% less volume than other comparable power relays.
- 1 Form A and 1 Form C arrangements in single and dual relay packages.
- Choice of AgNi 0.15 or AgSnO contacts.

Conditions

All parametric, environmental and life tests are performed according to EIA Standard RS-407-A at standard test conditions (23°C Ambient, 20-50% RH, 29.5 ± 1.0" Hg.) unless otherwise noted.

Contact Data

Arrangements: 1 Form A (SPST-NO) and 1 Form C (SPDT) in single relay and dual relay configurations.

Material: AgNi 0.15 - Recommended for inductive loads.
AgSnO - Recommended for high inrush, lamp and capacitive loads and applications prone to contact material transfer.

Max. Switching Rate: 20 operations per second with no contact load.
6 operations per minute for rated life at rated load.

Max. Load Current (@ 14VDC Load Voltage):

Load	Form A (NO)	Form C	
		NO	NC
Max. Continuous Current	30A	30A	25A
Max. Break Current	30A	30A	25A
Max. Make Current			
AgSnO	100A	100A	15A
AgNi 0.15	40A	40A	10A

Max. Switching Power: 35-320 watts DC (voltage dependent).

Min. Recommended Current: 0.5 amp @ 12VDC.

Initial Voltage Drop: 200 millivolts, maximum, for normally open contacts @ 10 amp contact load.
250 millivolts, maximum, for normally closed contacts @ 5 amp contact load.

Expected Life: 10 million operations, mechanical; 100,000 operations at 20 amps, 14VDC, resistive load on normally open contact.

Initial Dielectric Strength

Between Contacts and Coil: 500V rms.

Coil Data

Voltage: 12 VDC.

Resistance: See Coil Data table.

Nom. Power: 0.55 watts @ 23°C coil temp. and rated coil voltage.

Thermal Resistance: 50°C per actual coil watt in still air with no contact load current.

Coil Data (@ 23°C Coil Temperature)

Coil Designator	Rated Coil Voltage (VDC)	Coil Resistance ±10% (Ohms)	Must-Operate Voltage (VDC)	Must-Release Voltage (VDC)	Allowable ⁽¹⁾ Overdrive (VDC)	
					@ 23°C	@ 105°C
001	12	254	6.9	1.5	27.2	16.5

Dimensions are shown for reference purposes only.

Dimensions are in inches over (millimeters) unless otherwise specified.

Specifications and availability subject to change.

www.tycoelectronics.com
Technical support:
Refer to inside back cover.

Operate Data

Must Operate and Must Release Voltage: See Coil Data table.

Initial Operate Time: 3 milliseconds, typical, with rated coil voltage applied.

Initial Release Time: 1.5 milliseconds, typical, with zero volts applied (for unsuppressed relays after having been energized at rated coil voltage.)

Environmental Data

Temperature Range: Storage: -40°C to +155°C.

Operating: -40°C to +105°C.

Shock: 20g, 11 milliseconds, half sine wave pulse.

Vibration: (For NC contacts, NO contacts are significantly higher.)

10-40 Hz., 1.27mm double amplitude.

40-70 Hz., 5g's constant.

70-100 Hz., 0.5mm double amplitude.

100-500 Hz., 10g's constant.

Mechanical Data

Termination: Printed circuit terminals.

Enclosure: Immersion cleanable, sealed plastic cover.

Weight: Sealed: 4 gm (0.14 oz.) approximately.

Abnormal Operation

Overload Current: 50A, 5 sec.⁽²⁾

87.5A, 0.5 sec.

150A, 0.1 sec.

24V Jump Start: 24VDC for 5 minutes conducting rated contact current @ 23°C.

Drop Test: Capable of meeting specifications after a 1.0 meter drop onto concrete in final enclosure.

Flammability: UL94-HB or better (meets FMVSS 302).

Notes

- (1) Allowable overdrive is rated at ambient temperature of 23°C and 105°C as stated with no load current flowing through the relay contacts and minimum coil resistance with power applied for 30 sec. max. (20% max. duty cycle.)
- (2) Current and times are compatible with circuit protection by a typical 25A fuse. Relay will make, carry and break the specified current.

Figure 1 - Operating Voltage Range

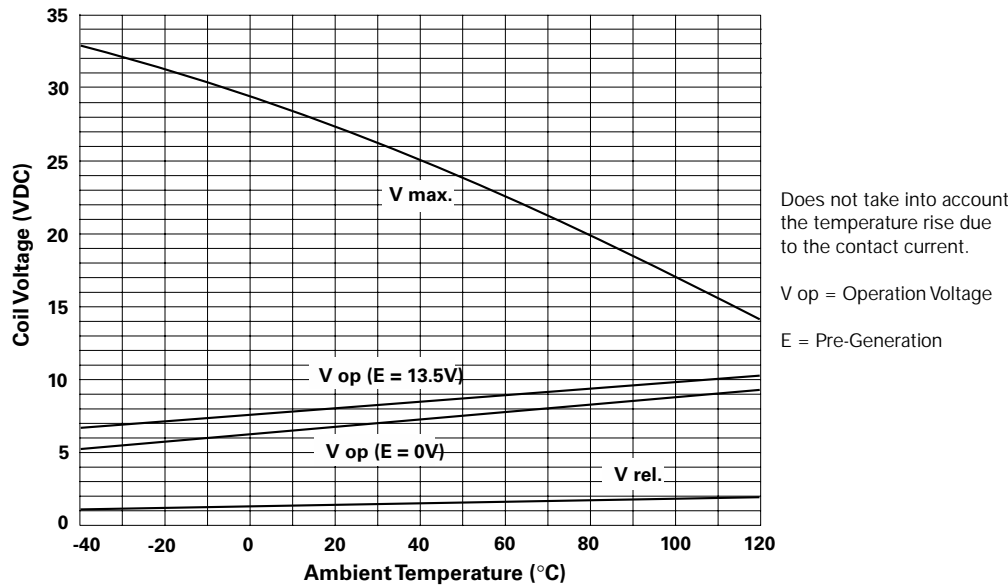

Ordering Information

Part Number	Contact Arrangement	Enclosure	Contact Materials
V23086-C1001-A303	1 Form C	Sealed, Plastic Cover	AgNi 0.15
V23086-C1001-A402	1 Form A	Sealed, Plastic Cover	AgSnO
V23086-C1001-A403	1 Form C	Sealed, Plastic Cover	AgSnO
V23086-C2001-A303	Dual Form C	Sealed, Plastic Cover	AgNi 0.15
V23086-C2001-A403	Dual Form C	Sealed, Plastic Cover	AgSnO

Our authorized distributors are more likely to maintain the following items in stock for immediate delivery.

- V23086-C1001-A303
- V23086-C1001-A403

Outline Dimensions – Single Relay

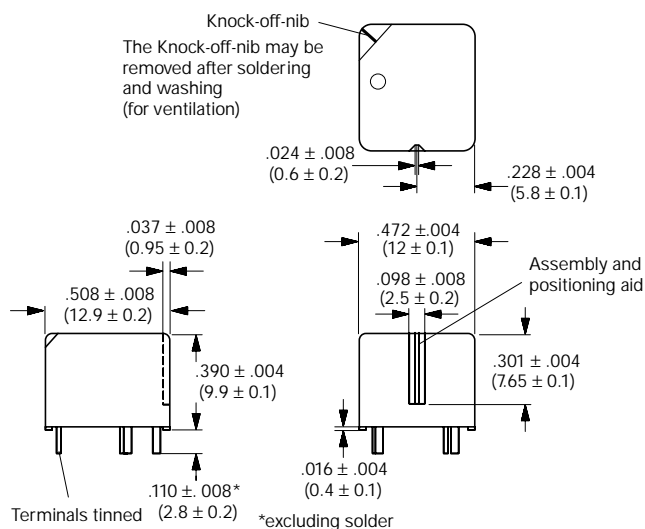

Wiring Diagrams – Single Relay (Bottom Views)

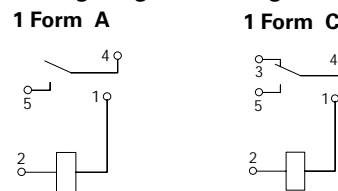

Suggested PC Board Layout – Single Relay (Bottom View)

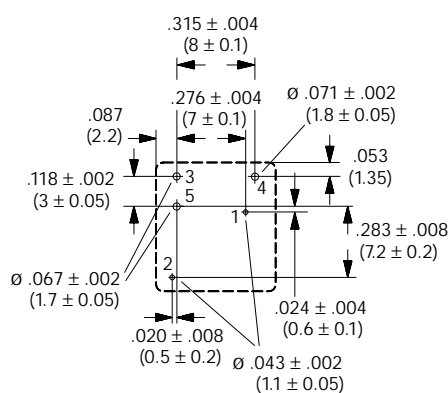

Dimensions are shown for reference purposes only.

Dimensions are in inches or (millimeters) unless otherwise specified.

Specifications and availability subject to change.

www.tycoelectronics.com
Technical support:
Refer to inside back cover.

Outline Dimensions – Dual Relay

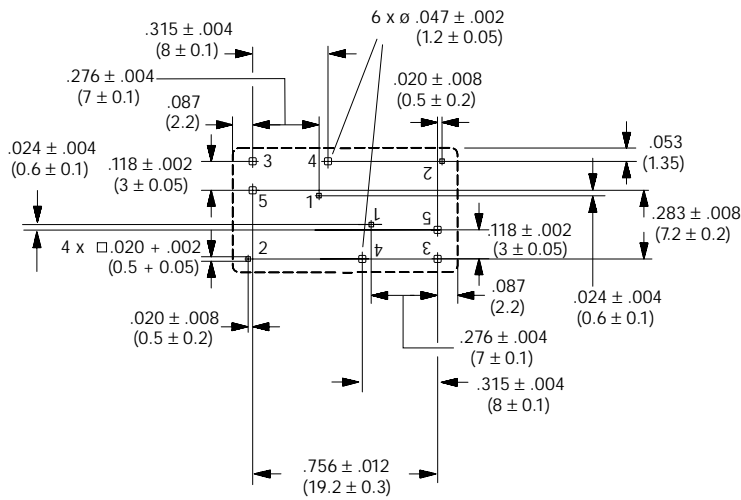
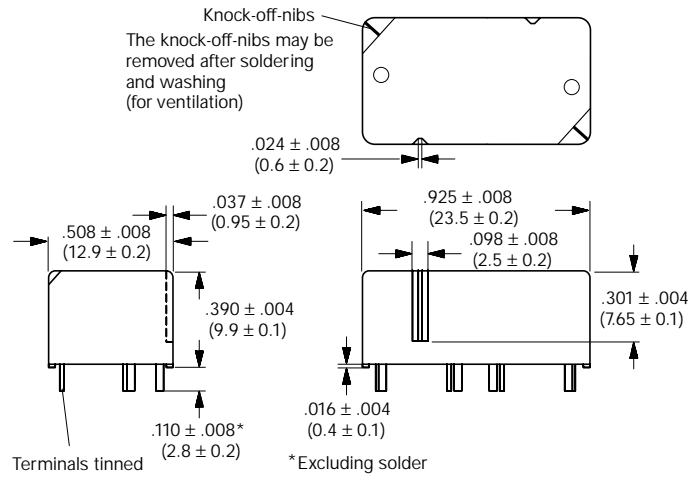

Wiring Diagrams - Dual Relay (Bottom Views)

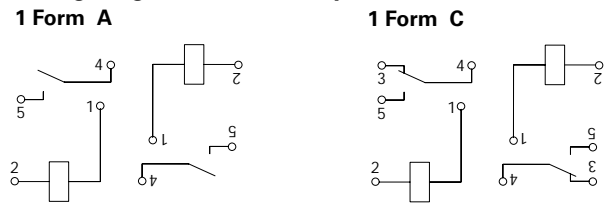

Suggested PC Board Mtg. Holes – Dual Relay (Bottom View)

See bottom view of relay (above) for hole-to-hole spacing

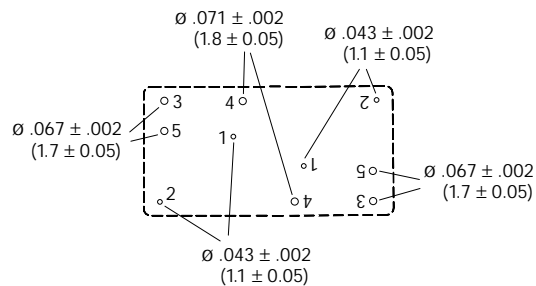



T72M series

20 Amp Miniature PC Board Relay for Automotive Applications

Users should thoroughly review the technical data before selecting a product part number. It is recommended that users also seek out the pertinent approvals files of the agencies/laboratories and review them to ensure the product meets the requirements for a given application.

Features

- 20A, 16VDC switching rating.
- 60A inrush at 16VDC.
- 15A continuous contact rating @ 105°C.
- Immersion cleanable plastic case with knock-off nib for ventilation.
- Low profile package has a seated height of only .67" (17mm).
- 1 Form C arrangement.
- Choice of AgNi 0.15 or AgSnO contacts.

Conditions

All parametric, environmental and life tests are performed according to EIA Standard RS-407-A at standard test conditions (23°C Ambient, 20-50% RH, 29.5 ± 1.0" Hg.) unless otherwise noted.

Contact Data

Arrangements: 1 Form C (SPDT).

Material: AgNi 0.15 - Recommended for inductive loads.

AgSnO - Recommended for high inrush, lamp and capacitive loads and applications prone to contact material transfer.

Max. Switching Rate: 20 operations per second with no contact load.

6 operations per minute for rated life at rated load.

Max. Switching Voltage: 75VDC(1).

Max. Load Current (@ 14VDC Load Voltage):

Load	Form C	
	NO	NC
Max. Continuous Current	20A	10A
Max. Break Current (1)	20A	20A
Max. Make Current (2)		
AgNi 0.15	60A	12A
AgSnO	80A	15A

Max. Switching Power: 35-320 watts DC (voltage dependent)(1).

Min. Recommended Current: 0.5 amp @ 12VDC.

Initial Voltage Drop: 200 millivolts, maximum, for normally open contacts @ 10 amp contact load.

250 millivolts, maximum, for normally closed contacts @ 5 amp contact load.

Expected Life: 10 million operations, mechanical; 100,000 operations at 20 amps, 14VDC, resistive load on normally open contact.

Initial Dielectric Strength

Between Contacts and Coil: 500V rms.

Coil Data

Voltage: 12 and 24VDC.

Resistance: See Coil Data table.

Nom. Power: 0.80 watts @ 23°C coil temp. and rated coil voltage.

Thermal Resistance: 50°C per actual coil watt in still air with no contact load current.

Coil Data (@23°C Coil Temperature)

Coil Designator	Rated Coil Voltage (VDC)	Coil Resistance ±10% (Ohms)	Coil Inductance (H) (Ref.)	Must-Operate Voltage (VDC)	Must-Release Voltage (VDC)	Allowable ⁽³⁾ Overdrive (VDC)	
						@ 23°C	@ 105°C
12	12	180	0.9	6.3	1.2	24.6	14.3
24	24	720	3.2	12.6	2.4	49.3	28.7

Dimensions are shown for reference purposes only.

Dimensions are in inches over (millimeters) unless otherwise specified.

Specifications and availability subject to change.

www.tycoelectronics.com
Technical support:
Refer to inside back cover.

Operate Data

Must Operate and Must Release Voltage: See Coil Data table.

Initial Operate Time: 5 milliseconds, typical, with rated coil voltage applied.

Initial Release Time: 2 milliseconds, typical, with zero volts applied (for unsuppressed relays after having been energized at rated coil voltage.)

Environmental Data

Temperature Range: Storage: -40°C to +155°C.

Operating: -40°C to +105°C(4).

Shock: 20g, 11 milliseconds, half sine wave pulse.

Vibration: (For NC contacts, NO contacts are significantly higher.)

10-40 Hz., 1.27mm double amplitude.

40-70 Hz., 5g's constant.

70-100 Hz., 0.5mm double amplitude.

100-500 Hz., 10g's constant.

Mechanical Data

Termination: Printed circuit terminals.

Enclosure: Immersion cleanable, sealed plastic cover.

Weight: Sealed: 12 gm (0.4 oz.) approximately.

Audible Sound: 95dBA @ 10 cm, 14VDC coil voltage.
77dBA @ 1 M, 14VDC coil voltage.

Abnormal Operation

Overload Current: 40A, 36 sec.⁽⁵⁾

80A, 10 sec.

150A, 2.5 sec.

24V Jump Start: 24VDC for 5 minutes conducting rated contact current @ 23°C.

Drop Test: Capable of meeting specifications after a 1.0 meter drop onto concrete in final enclosure.

Flammability: UL94-HB or better (meets FMVSS 302).

Notes

(1) See Figure 1.

(2) Inrush current for lamp load.

(3) Allowable overdrive is rated at ambient temperature of 23°C and 105°C as stated with a 10A load current flowing through the relay contacts and minimum coil resistance with power applied for 30 sec. max. (20% max. duty cycle.) For continuous duty information, see Figure 2. (Ambient Temperature vs. Coil Voltage for Continuous Duty.)

(4) See Figure 2.

(5) Current and times are compatible with circuit protection by a typical 20A circuit breaker. Relay will make, carry and break the specified current.

Figure 1 - Limiting Curve for Power Load

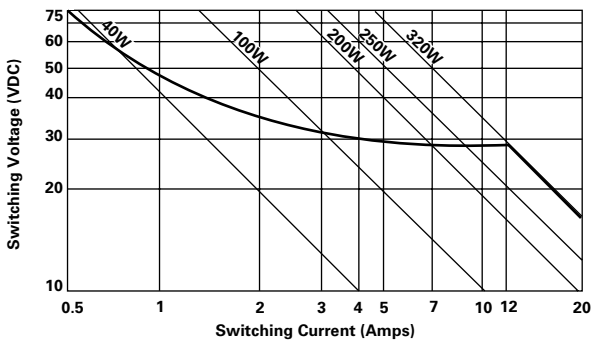

Safe breaking, arc extinguished (normally open contact) for resistive loads.

Figure 2 - Ambient Temperature vs. Coil Voltage for Continuous Duty

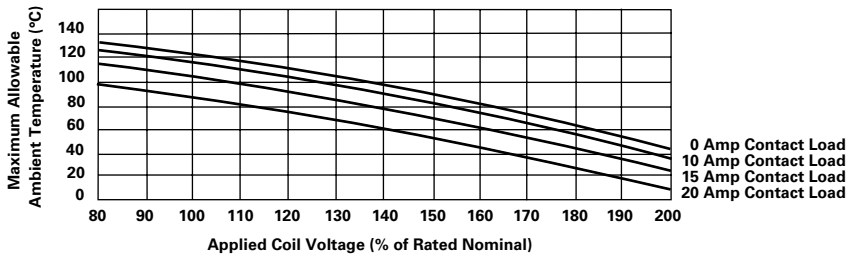

Assumptions:

1. Thermal resistance = 50°C per watt
2. Still air
3. Nominal coil resistance
4. Maximum mean coil temperature = 155°C
5. Coil temperature rise due to load
 - = 8°C @ 10 amps
 - = 20°C @ 15 amps
 - = 35.5°C @ 20 amps
6. Curves are based on 800mW at 23°C
7. When full lifetime is at high ambient and high load current, subtract 25°C from maximum allowable ambient temperature.

Ordering Information

Part Number	Contact Arrangement	Enclosure	Contact Materials
T72M5D121-*	1 Form C	Sealed, Plastic Cover	AgNi 0.
T72M5D155-*	1 Form C	Sealed, Plastic Cover	AgSnO

*Standard Coil Voltages: 12 = 12VDC
24 = 24VDC (Consult factory for availability).

Our authorized distributors are more likely to maintain the following items in stock for immediate delivery.

None at present.

Outline Dimensions

Tolerance (unless otherwise noted): 3 decimal: ± .010 (± .254); 2 decimal: ± .015 (± .381).

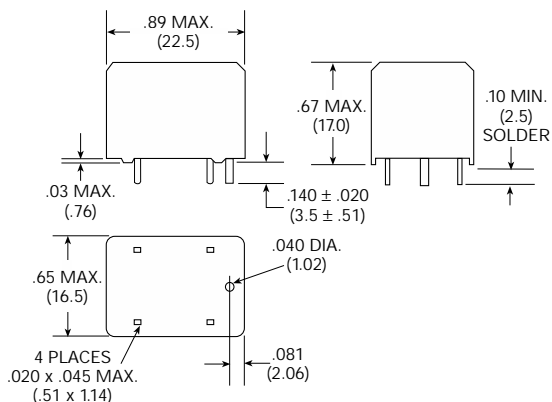

Wiring Diagram (Bottom View)

Code 5
1 Form C

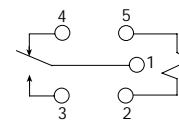

Suggested PC Board Layout (Bottom View)

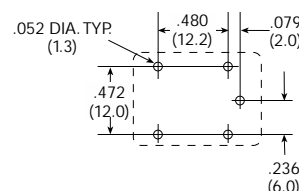

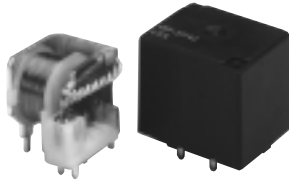

VKP series

Compact, 40 Amp, Open or Sealed PC Board Relay For Automotive Applications

Users should thoroughly review the technical data before selecting a product part number. It is recommended that users also seek out the pertinent approvals files of the agencies/laboratories and review them to ensure the product meets the requirements for a given application.

Features

- 40A continuous contact rating @ 85°C.
- 1 Form A and 1 Form C arrangements.
- PC board terminals.
- Available as open frame or sealed relay.
- Choice of AgNi 0.15 or AgSnO contacts.

Conditions

All parametric, environmental and life tests are performed according to EIA Standard RS-407-A at standard test conditions (23°C Ambient, 20-50% RH, 29.5 ± 1.0" Hg.) unless otherwise noted.

Contact Data

Arrangements: 1 Form A (SPST-NO) and 1 Form C (SPDT).

Material: AgNi 0.15 – Recommended for inductive loads.
AgSnO – Recommended for high inrush, lamp and capacitive loads and applications prone to contact material transfer.

Max. Switching Rate: 20 operations per second with no contact load.
6 operations per minute for rated life at rated load.

Max. Switching Voltage: 75VDC (1).

Max. Load Current (@ 14VDC Load Voltage):

Load		Form A (NO)	Form C	
			NO	NC
Max. Continuous Current	Open Frame	45A	45A	30A
	Sealed Cover	45A	45A	30A
Max. Break Current (1)		60A	60A	30A
Max. Make Current (2)				
AgNi 0.15		100A	100A	30A
AgSnO		180A	180A	30A

Max. Switching Power: 50-500 watts DC (voltage dependent) (1).

Min. Recommended Current: 1 amp @ 12VDC.

Initial Voltage Drop: 200 millivolts, maximum, for normally open contacts @ 40 amp contact load.
250 millivolts, maximum, for normally closed contacts @ 20 amp contact load.

Expected Life: 10 million operations, mechanical; 100,000 operations at 40 amps, 14VDC, resistive load on normally open contact.

Initial Dielectric Strength

Between Contacts and Coil: 500V rms.

Coil Data

Voltage: 12 and 24VDC.

Resistance: See Coil Data table.

Nom. Power: 1.6 watts @ 23°C coil temp. and rated coil voltage.

Thermal Resistance: 45°C per actual coil watt in still air with no contact load current.

Coil Data (@ 23°C Coil Temperature)

Coil Designator	Rated Coil Voltage (VDC)	Coil Resistance ±10% (Ohms)	Coil Inductance (H) (Ref.)	Must-Operate Voltage (VDC)	Must-Release Voltage (VDC)	Allowable (3) Overdrive (VDC)	
						@ 23°C	@ 85°C
F	12	90	0.6	6.8	1.2	19.6	14.3
H	24	362	2.3	13.9	2.4	39.3	28.6

Dimensions are shown for reference purposes only.

Dimensions are in inches over (millimeters) unless otherwise specified.

Specifications and availability subject to change.

www.tycoelectronics.com
Technical support:
Refer to inside back cover.

Operate Data

Must Operate and Must Release Voltage: See Coil Data table.

Initial Operate Time: 5 milliseconds, typical, with rated coil voltage applied.

Initial Release Time: 3 milliseconds, typical, with zero volts applied (for unsuppressed relays after having been energized at rated coil voltage).

Environmental Data

Temperature Range: Storage: -40°C to +155°C.

Operating: -40°C to +125°C (4).

Shock: 20g, 11 milliseconds, half sine wave pulse.

Vibration: (For NC contacts, NO contacts are significantly higher.)

10-40 Hz., 1.27mm double amplitude.

40-70 Hz., 5g's constant.

70-100 Hz., 0.5mm double amplitude.

100-500 Hz., 10g's constant.

Mechanical Data

Termination: Printed circuit terminals.

Enclosure: Sealed relay is suitable for immersion cleaning of PCB assembly or conformal coating. Relay may be vented after cleaning by cutting the vent projection from the corner of the relay after processing using a razor knife or equivalent.

Weight: 20g (0.7 oz.) approximately.

Abnormal Operation

Overload Current: Consult factory.

24V Jump Start: 24VDC for 5 minutes conducting rated contact current @ 23°C.

Drop Test: Capable of meeting specifications after a 1.0 meter drop onto concrete in final enclosure.

Flammability: UL94-HB or better, internal parts (meets FMVSS 302).

Notes

(1) See Figure 1.

(2) Inrush current for lamp load.

(3) Allowable overdrive is rated at ambient temperature for 23°C or 85°C as stated with no load current flowing through the relay contacts and minimum coil resistance. Also see Figure 2 for maximum ambient temperature versus applied coil voltage.

(4) See Figure 2.

(5) Current and times are compatible with circuit protection by a typical automotive circuit breaker. Relay will make, carry and break the specified current.

Figure 1 – Limiting Curve for Power Load

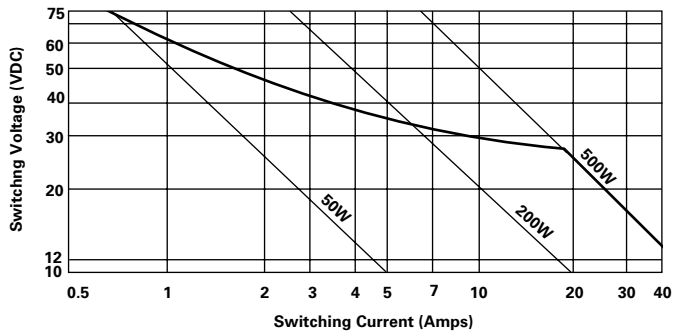

Safe breaking, arc extinguished (normally open contact) for resistive loads.

Figure 2 – Ambient Temperature vs. Coil Voltage for Continuous Duty

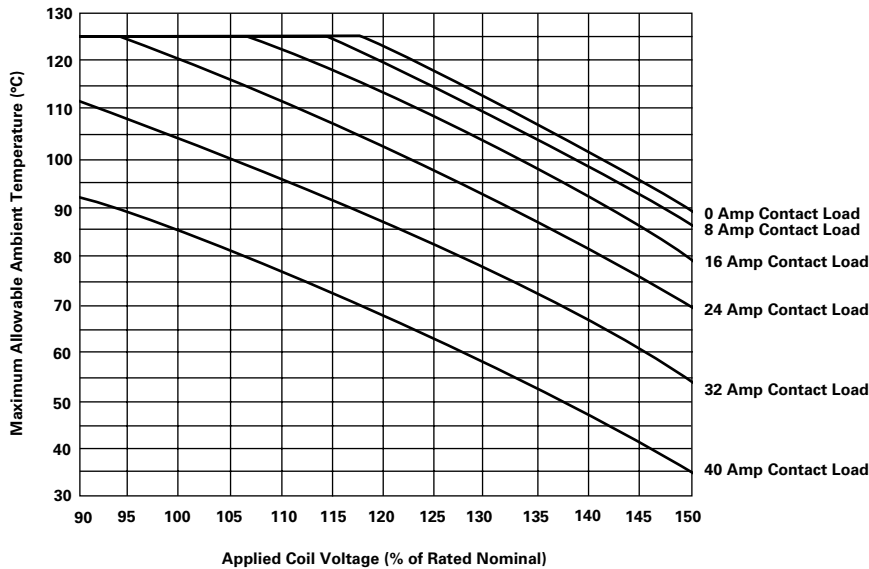

Assumptions:

1. Thermal resistance = 40°C per watt.
2. Still air.
3. Nominal coil resistance.
4. Maximum mean coil temperature = 180°C.
5. Coil temperature rise due to load.
 - = 3.5°C @ 8 amps.
 - = 10°C @ 16 amps.
 - = 20°C @ 24 amps.
 - = 36°C @ 32 amps.
 - = 55°C @ 40 amps.
6. Thermal resistance and power dissipation based on coil resistance at 180°C.
7. Curves are based on 1.6 watts at 23°C.
8. When full lifetime is at high ambient and high load current, subtract 25°C from maximum allowable ambient temperature.
9. Data is for open relays.
10. Subtract 10°C from the maximum allowable ambient temperature for sealed version.

Ordering Information

Part Number	Contact Arrangement	Contact Material	Enclosure	Termination Footprint
VKP-11 * 42	1 Form A	AgNi 0.15	Open	U.S.A.
VKP-15 * 42	1 Form C	AgNi 0.15	Open	U.S.A.
VKP-11 * 52	1 Form A	AgSnO	Open	U.S.A.
VKP-15 * 52	1 Form C	AgSnO	Open	U.S.A.
VKP-31 * 42	1 Form A	AgNi 0.15	Immersion Cleanable Case	U.S.A.
VKP-35 * 42	1 Form C	AgNi 0.15	Immersion Cleanable Case	U.S.A.
VKP-31 * 52	1 Form A	AgSnO	Immersion Cleanable Case	U.S.A.
VKP-35 * 52	1 Form C	AgSnO	Immersion Cleanable Case	U.S.A.

*Standard Coil Voltages: F = 12VDC
H = 24VDC (Consult factory for availability)

Our authorized distributors are more likely to maintain the following items in stock for immediate delivery.

None at present.

Note: See page 1011 for Wiring Diagrams, Suggested PC Board Layouts and Outline Dimensions.

New Relay for Flashing Lamp Applications

Features

- 30A flashing lamp rating up to 85°C.
- Long life for flashing lamp load applications.
- 1 Form A and 1 Form C arrangements.
- Available as open frame or sealed relay.
- Choice of standard or high current model.

Conditions

All parametric, environmental and life tests are performed according to EIA Standard RS-407-A at standard test conditions (23°C Ambient, 20-50% RH, 29.5 ± 1.0" Hg.) unless otherwise noted.

Contact Data

Arrangements: 1 Form A (SPST-NO) and 1 Form C (SPDT).

Material: PdCu/AgNi 0.15.

Max. Switching Rate: 20 operations per second with no contact load.
90 operations per minute for rated life at rated load.
270 operations per minute for passenger car lamp outage indication.

Max. Switching Voltage: 28VDC.

Max. Load Current (@ 14VDC Load Voltage):

Standard Current Types				
Load		Form A (NO)	Form C	
			NO	NC
Steady-State Flashing ⁽¹⁾	Open Frame	15A	15A	5A
	Sealed Cover	12A	12A	5A
Alternate Flashing ⁽²⁾	Open Frame	-	4A	4A
	Sealed Cover	-	4A	4A
Max. Make Current ⁽³⁾		120A	120A	30A
Max. Break Current		20A	20A	10A

High Current Types				
Load		Form A (NO)	Form C	
			NO	NC
Steady-State Flashing	Open Frame	30A	30A	10A
	Sealed Cover	25A	25A	10A
Alternate Flashing	Open Frame	-	8A	8A
	Sealed Cover	-	8A	8A
Max. Make Current ⁽³⁾		240A	240A	60A
Max. Break Current		30A	30A	20A

Min Recommended Current: 1 amp @ 12VDC.

Initial Voltage Drop: 100 millivolts, maximum, for normally open contacts @ 10A contact load.
200 millivolts, maximum, for normally closed contacts @ 10A contact load.

Expected Life: Mechanical Life: 10 million operations.

Electrical Life: (See application information.)

Electrical Isolation

Dielectric Strength (coil to contacts): 500 Vrms.

Coil Data (@ 23°C Coil Temperature)

Coil Designator	Rated Coil Voltage (VDC)	Coil Resistance ±10% (Ohms)	Coil Inductance (H) (Ref.)	Must-Operate Voltage (VDC)	Must-Release Voltage (VDC)	Allowable ⁽⁴⁾ Overdrive (VDC)	
						@ 23°C	@ 85°C
F	12	90	0.6	6.8	1.2	19.6	14.3
H	24	362	2.3	13.9	2.4	39.3	28.6

VKP series

PC Board Relay

Coil Data

Voltage: 12 and 24VDC.

Resistance: See Coil Data table.

Nom. Power: 1.6 watts @ 23°C coil temp. and rated coil voltage.

Thermal Resistance: 45°C per actual coil watt in still air with no contact load current.

Operate Data

Must Operate and Must Release Voltage: See Coil Data table.

Initial Operate Time: 5 milliseconds, typical, with rated coil voltage applied.

Initial Release Time: 3 milliseconds, typical, with zero volts applied (for unsuppressed relays after having been energized at rated coil voltage).

Environmental Data

Temperature Range: Storage:

Open Types: -40°C to +155°C.

Sealed Types: -40°C to +125°C.

Operating: -40°C to 125°C⁽⁴⁾.

Shock: 20g, 11 milliseconds, half sine wave pulse.

Vibration: (For NC contacts, NO contacts are significantly higher.)

10-40 Hz., 1.27mm double amplitude.

40-70 Hz., 5g's constant.

70-100 Hz., 0.5mm double amplitude.

100-500 Hz., 10g's constant.

Mechanical Data

Termination: Printed circuit terminals. (U.S.A. footprint style only)

Enclosure: Sealed relay is suitable for immersion cleaning of PCB assembly or conformal coating. Relay may be vented cutting the vent projection from the corner of the relay after processing using razor knife or equivalent.

Weight: 20g (0.7 oz.) approximately.

Abnormal Operation

Overload Current: Consult factory.

24V Jump Start: 24VDC for 5 minutes conducting rated contact current @ 23°C.

Drop Test: Capable of meeting specifications after a 1.0 meter drop onto concrete in final enclosure.

Flammability: UL94-HB or better (meets FMVSS 302).

Notes

- (1) Continuous On-Off cycling of a single set of lamps at 60 to 90 cycles per minute and approximately a 50% duty cycle.
- (2) Continuous cycling between two sets of lamps with one set switched by the N.O. contacts and the other by the N.C. contacts, at 60 to 90 cycles per minute and approximately a 50% duty cycle.
- (3) Inrush current for lamp load.
- (4) Allowable overdrive is rated at ambient temperature for 23°C or 85°C as stated with no load current flowing through the relay contacts and minimum coil resistance. Also see Figure 2 for maximum ambient temperature versus applied coil voltage.
- (5) Current and times are compatible with circuit protection by a typical automotive circuit breaker. Relay will make, carry and break the specified current.

Application Information

Load Polarity: VKP series relays for flashing lamp applications are constructed with Palladium-Copper movable contacts and fine grain silver stationary contacts. This causes the relay to be sensitive to the polarity of the load voltage. This type of VKP relay must be mechanized in the circuit such that the more positive connection is made to the movable contact (identified as terminal 4 in the wiring diagrams). Failure to do so will nullify the benefit of the Palladium Copper and will result in contact welding.

Typical Applications: VKP series relays for flashing lamp applications are typically used for turn signal, hazard warning, emergency vehicle, and security system applications. They may also be used for high in-rush current capacitive loads such as audio amplifiers. Use on inductive loads or loads with high continuous load currents should be avoided. The relay should also not be used for applications which do not have a significant make current as high contact voltage drop may result.

Standard Current Relays: VKP series relays for flashing lamp applications which are indicated as "standard current" units are generally suitable for passenger car and light truck applications for turn signal, hazard warning, or combination flashers (with or without normal trailering requirements) for 2 or 3 bulb turn signal systems. They are also generally suitable for security system applications for lamp flashing and for most audio amplifier applications.

High Current Relays: VKP series relays for flashing lamp applications which are designated as "high current" have larger contacts, a larger shunt connecting the movable contacts to the output terminals, and other performance enhancing characteristics to provide longer life and provide higher current carrying capacity. This type relay should be used for truck applications which have greater load current and in applications such as emergency vehicle lighting and service vehicle hazard warning lights which have very high cycle life requirements. The high current versions are also recommended for most alternating flasher applications, as this version has much improved performance of the normally closed contact. However, optimum life can be obtained for alternating applications by using two normally open relays and powering the coils alternately.

Electrical Life Test Information

Standard Current Relays: 3 bulb T/S (turn signal) system, combined turn signal and hazard warning with normal trailering (test requirements):

3 bulb	1.8 million operations
4 bulb	130 K operations
6 bulb	194 K operations
8 bulb	248 K operations
TOTAL	2.3 million operations

This application represent about the limit of the performance capability of the "standard current" types and is generally the limit of the industry requirement for passenger car applications.

Note: Bulb as used here is a 27 watt turn signal bulb, trade #1156. Testing includes operations at -40°C, 23°C, and 85°C.

High Current Relays: 3 bulb T/S system, combined turn signal and hazard warning with special trailering (test requirements):

3 bulb	2.1 million operations
6 bulb	194 K operations
7 bulb	259 K operations
14 bulb	497 K operations
TOTAL	3.0 million operations

This application represent about the limit of the performance capability of the "high current" types. It should be noted that the low current operations have very little affect on the total product life where as the 14 bulb (33 ampere) operations are extremely destructive. Units test on 14 bulb (only) loads can be expected to fail at less than 1 million operations.

Note: Bulb as used here is a 27 watt turn signal bulb, trade #1156. Testing includes operations at -40°C, 23°C, and 85°C.

Design Considerations: It should be noted that although the VKP series relays are capable of handling relatively high currents, when applying the product under high current and high ambient temperature conditions, providing adequate conductor volume is critical, as is the solder connection, particularly with respect to the normally open contact terminal. It may be necessary to use high temperature solder, a plated through hole PCB, or a copper lead frame type construction under these conditions to prevent failure of the solder joint.

Figure 2 – Ambient Temperature vs. Coil Voltage for Continuous Flashing at 50% Duty Cycle (Steady Current, Open Style)

Consult factory.

Ordering Information

Part Number	Contact Arrangement	Contact Material	Enclosure	Load Ratings
VKP-11 * 32	1 Form A	PdCu/AgNi 0.15	Open	Standard Current
VKP-11 * 62	1 Form A	PdCu/AgNi 0.15	Open	High Current
VKP-15 * 62	1 Form C	PdCu/AgNi 0.15	Open	High Current
VKP-31 * 32	1 Form A	PdCu/AgNi 0.15	Immersion Cleanable Case	Standard Current
VKP-31 * 62	1 Form A	PdCu/AgNi 0.15	Immersion Cleanable Case	High Current
VKP-35 * 62	1 Form C	PdCu/AgNi 0.15	Immersion Cleanable Case	High Current

*Standard Coil Voltages: F = 12VDC
H = 24VDC (Consult factory for availability)

Our authorized distributors are more likely to maintain the following items in stock for immediate delivery.

None at present.

Outline Dimensions

Open Model

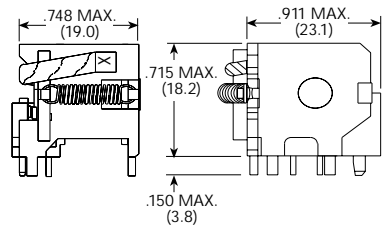

Sealed Model

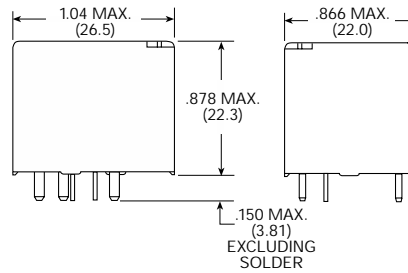

Wiring Diagrams (Bottom Views)

Open Models

1 Form A

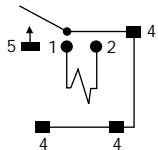

1 Form C

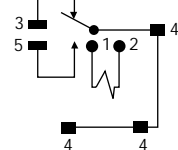

Sealed Models

1 Form A

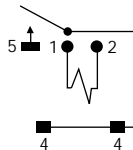

1 Form C

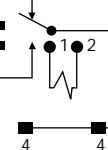

Suggested PC Board Layouts (Bottom Views)

Open Model

Hole Size

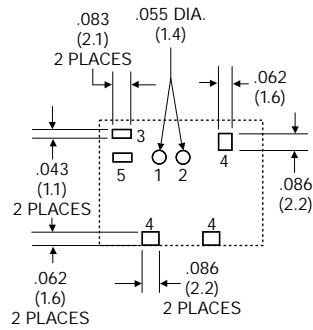

Sealed Model

Hole Size

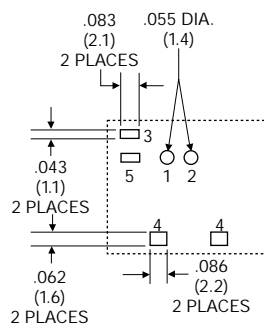

Center-To-Center

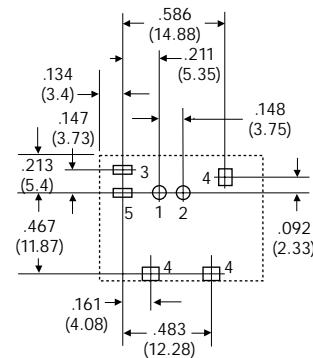

Center-To-Center

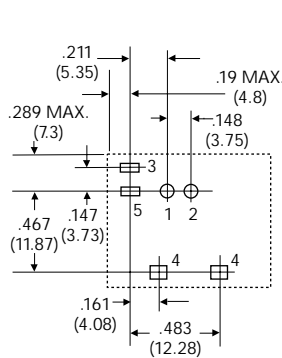
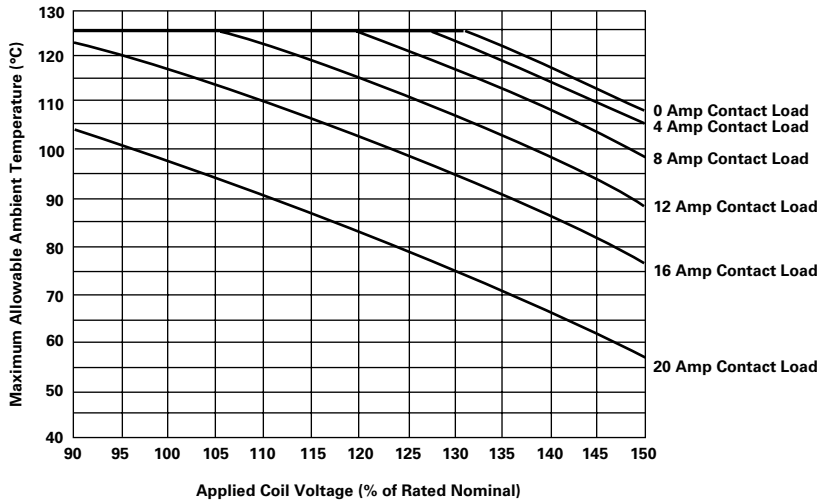

Figure 1 - Limiting Curve for Power Load

At present, these data are still to be determined.

Figure 2 - Ambient Temperature vs. Coil Voltage for Continuous Duty



Assumptions:

1. Thermal resistance = 55°C per watt
2. Still air
3. Nominal coil resistance (150Ω)
4. Maximum mean coil temperature = 180°C
= 3°C @ 4 amps
= 9°C @ 8 amps
= 19°C @ 12 amps
= 31°C @ 16 amps
= 51°C @ 20 amps
5. Coil temperature rise due to load
6. Thermal resistance and power dissipation based on coil resistance at 180°C
7. Curves are based on 0.96 watts at 23°C
8. When full lifetime is at high ambient and high load current, subtract 25°C from maximum allowable ambient temperature.

Ordering Information

Part Number	Coil Resistance
V2R-1001	150Ω

Typical Application Schematic

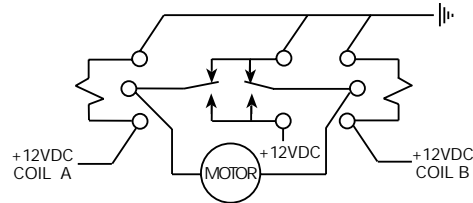

Our authorized distributors are more likely to maintain the following items in stock for immediate delivery.

None at present.

Outline Dimensions

Tolerance (unless otherwise noted): 3 decimal: ± .010 (±.254); 2 decimal: ± .015 (±.381).

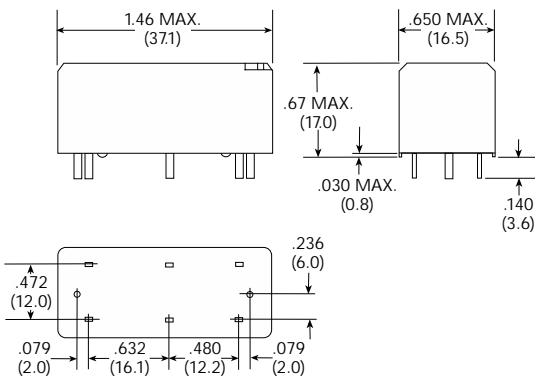

Wiring Diagram (Bottom View)

2 x 1 Form C (H-Bridge)

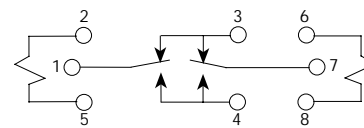

Suggested PC Board Layout

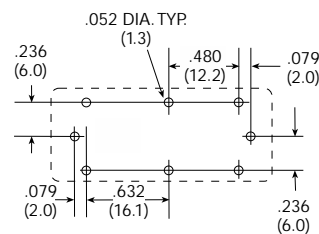



VFM series

20 Amp Relay With Quick Connect Terminals for Automotive Applications

Users should thoroughly review the technical data before selecting a product part number. It is recommended that users also seek out the pertinent approvals files of the agencies/laboratories and review them to ensure the product meets the requirements for a given application.

Features

- 20A continuous contact rating @ 85°C.
- 1 Form A and 1 Form C arrangements.
- Plug-in terminals.
- Plastic enclosure.

Conditions

All parametric, environmental and life tests are performed according to EIA Standard RS-407-A at standard test conditions (23°C Ambient, 20-50% RH, 29.5 ± 1.0" Hg.) unless otherwise noted.

Contact Data

Arrangements: 1 Form A (SPST-NO) and 1 Form C (SPDT).
Material: AgNi 0.15 and AgSnO (consult factory for other contact materials).
Max. Switching Rate: 20 operations per second with no contact load.
 6 operations per minute for rated life at rated load.
Max. Switching Voltage: 75VDC⁽¹⁾.
Max. Load Current (@ 14VDC Load Voltage):

Load	Form A (NO)	Form C	
		NO	NC
Max. Continuous Current	20A	20A	10A
Max. Make Current	120A(2)	120A(2)	40A
Max. Break Current ⁽¹⁾	30A	30A	15A

Max. Switching Power: 35-250 watts DC (voltage dependent⁽¹⁾).

Min. Recommended Current: 1.0 amp @ 12VDC.

Initial Voltage Drop: 200 millivolts, maximum, for normally open contacts @ 15 amp contact load.
 250 millivolts, maximum, for normally closed contacts @ 10 amp contact load.

Expected Life: 10 million operations, mechanical; 100,000 operations at 20 amps, 14VDC, resistive load on normally open contact.

Initial Dielectric Strength

Between Contacts and Coil: 500V rms.

Coil Data

Voltage: 12VDC.

Resistance: See Coil Data table.

Nom. Power: (@ 23°C coil temp. and rated coil voltage.):
 1.6W, unswitched.
 1.81W, with 680 ohm resistor.

Thermal Resistance: 50°C per actual coil watt in still air with no contact load current.

Coil Data (@ 23°C Coil Temperature)

Coil Designator (VDC)	Rated Coil Voltage (VDC)	Coil Resistance ±10% (Ohms)	Coil Inductance (H) (Ref.)	Must-Operate Voltage (VDC)	Must-Release Voltage (VDC)	Allowable ⁽³⁾ Overdrive	
						@ 23°C	@ 85°C
F	12	90	0.5	7.2	1.2	20.4	14.9

Operate Data

Must Operate and Must Release Voltage: See Coil Data table.

Initial Operate Time: 4 milliseconds, typical, with rated coil voltage applied.

Initial Release Time: 1.5 milliseconds, typical, with zero volts applied (for unsuppressed relays after having been energized at rated coil voltage).

Environmental Data

Temperature Range: Storage: -40°C to +155°C.

Operating: -40°C to +125°C⁽⁴⁾.

Shock: 10g, 11 milliseconds, half sine wave pulse.

Vibration: (For NC contacts, NO contacts are significantly higher.)

10-40 Hz., 1.27mm double amplitude.

40-70 Hz., 5g's constant.

70-100 Hz., 0.5mm double amplitude.

100-500 Hz., 10g's constant.

Mechanical Data

Termination: Quick connect.

Enclosure: Plastic dust cover.

Weight: With QC terminals: 20g (0.7 oz.) approximately.

Abnormal Operation

Overload Current: 40A, 36 sec.⁽⁵⁾

80A, 10 sec.

200A, 2.5 sec.

24V Jump Start: 24VDC for 5 minutes conducting rated contact current @ 23°C.

Drop Test: Capable of meeting specifications after a 3.28 foot (1.0 meter) drop onto concrete in final enclosure.

Flammability: UL94-HB or better (meets FMVSS 302).

Notes

(1) See Figure 1.

(2) Inrush current for lamp load.

(3) Allowable overdrive is rated at ambient temperature for 23°C or 85°C as stated with no load current flowing through the relay contacts and minimum coil resistance. Also see Figure 2 for maximum ambient temperature versus applied coil voltage.

(4) See Figure 2.

(5) Current and times are compatible with circuit protection by a typical 20A automotive circuit breaker. Relay will make, carry and break the specified current.

Figure 1 – Limiting Curve for Power Load

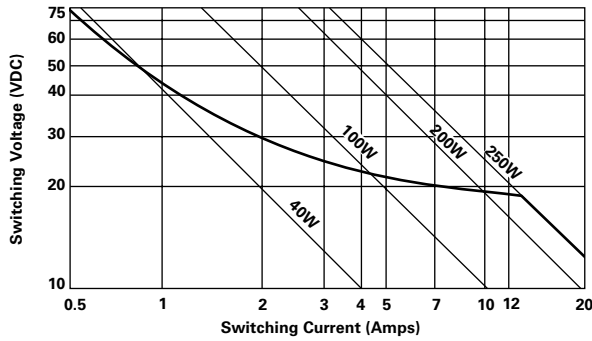

Safe breaking, arc extinguished (normally open contact) for resistive loads.

Figure 2 – Ambient Temperature vs. Coil Voltage for Continuous Load

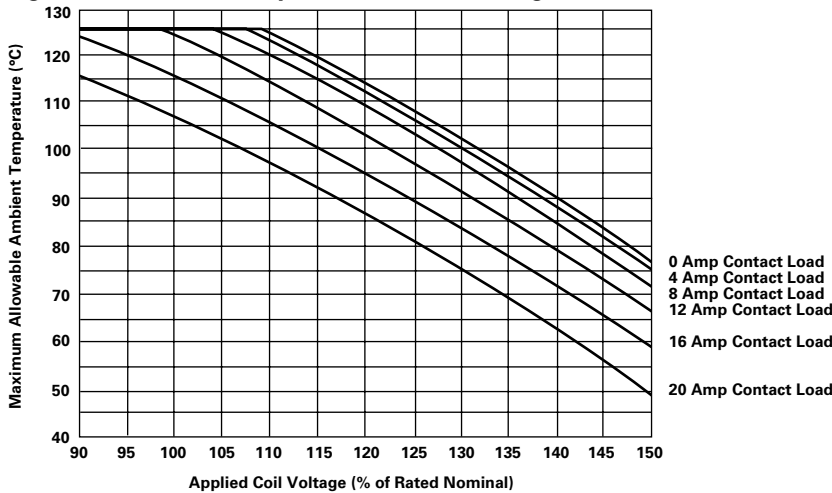

Assumptions:

1. Thermal resistance = 50°C per watt
2. Still air
3. Nominal coil resistance
4. Maximum mean coil temperature = 180°C
5. Coil temperature rise due to load
 - = 1°C @ 4 amps
 - = 4.5°C @ 8 amps
 - = 9.5°C @ 12 amps
 - = 18°C @ 16 amps
 - = 26.5°C @ 20 amps
6. Thermal resistance and power dissipation based on coil resistance at 180°C
7. Curves are based on 1.5 watts at 23°C
8. When full lifetime is at high ambient and high load current, subtract 25°C from maximum allowable ambient temperature.

Ordering Information

Part Number	Contact Arrangement	Terminals	Contact Material
VFM-11F21	1 Form A	Quick connect	AgNi 0.15
VFM-11F41	1 Form A	Quick connect	AgSnO
VFM-15F21	1 Form C	Quick connect	AgNi 0.15
VFM-15F41	1 Form C	Quick connect	AgSnO

*Standard Coil Voltages: F = 12VDC

Optional Coil Suppression

Add suffix -S01 for 680 ohm resistor in parallel with 12VDC coil.

Our authorized distributors are more likely to maintain the following items in stock for immediate delivery.

None at present..

Outline Dimensions

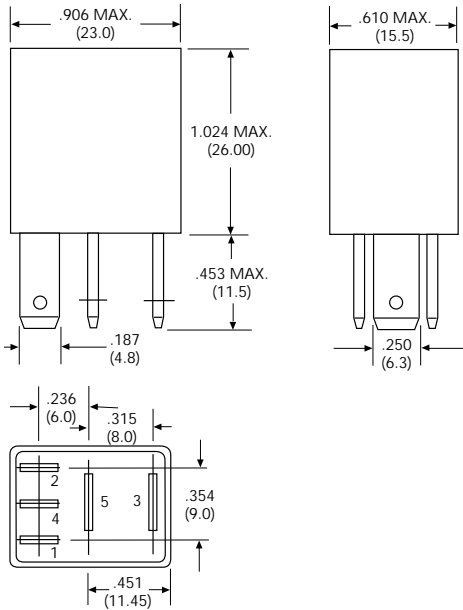

Wiring Diagrams (Bottom Views)

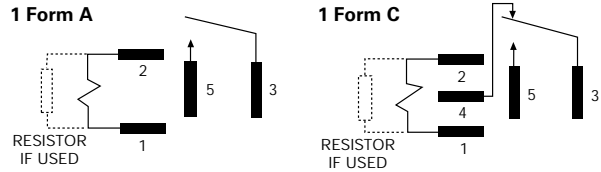

Connector

Connectors For Use With VFM Relays

**PC Board Socket
VCFM-1000**

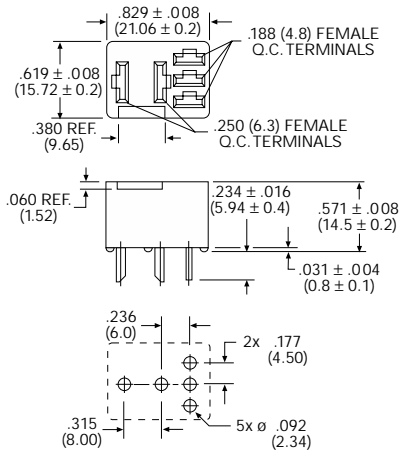

**Wire Harness Style, Bracket Mount Socket (Order Terminals Separately)
VCFM-1002**

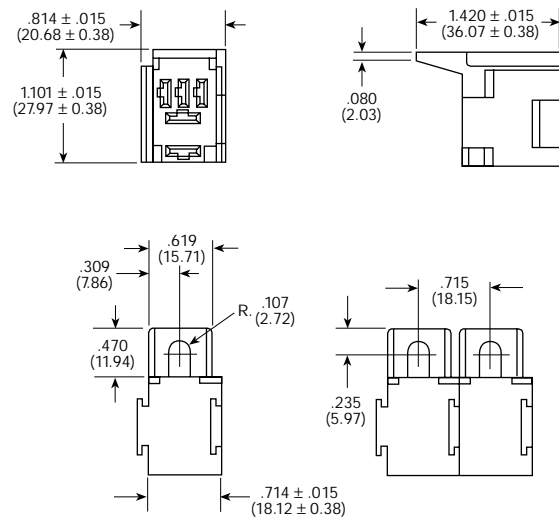

Connector/Terminal Usage Chart - Boldface items are stocked.

Connector	Terminal P/N	Required Crimp Terminals (Order Separately)					
		Alternate P/N	Wire AWG	Qty. Required		Use in Cavities	
				Form A	Form C	Form A	Form C
VCFM-1000	None	None	N/A	N/A	N/A	N/A	N/A
VCFM-1002	26A1349A	AMP 60249-1	12-16				
	26A1349B	AMP 42281-1	14-18	2	2	3 & 5	3 & 5
	26A1492A	G&H K26313	15-20				
	26A1492B	G&H K26312	14-16	2	3	1 & 2	1, 2 & 4

Figure 1 – Limiting Curve for Power Load

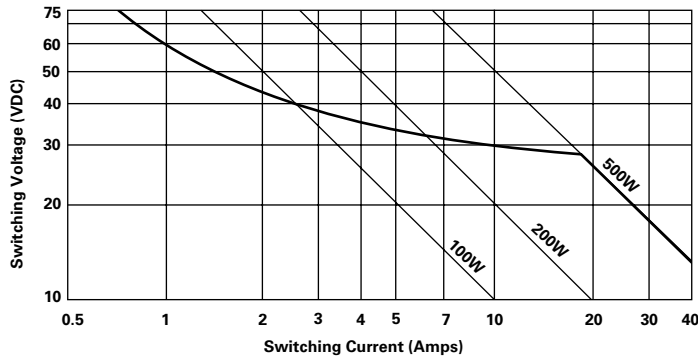

Safe breaking, arc extinguished (normally open contact) for resistive loads.

Figure 2 – Ambient Temperature vs. Coil Voltage for Continuous Duty

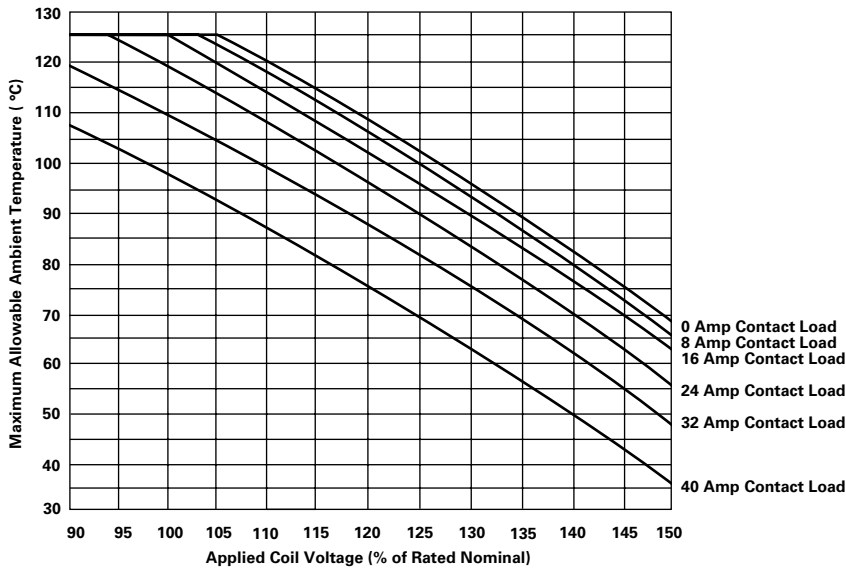

Assumptions:

1. Thermal resistance = 50°C per watt
2. Still air
3. Nominal coil resistance
4. Maximum mean coil temperature = 180°C
5. Coil temperature rise due to load
 - = 2°C @ 8 amps
 - = 5°C @ 16 amps
 - = 11°C @ 24 amps
 - = 20°C @ 32 amps
 - = 32°C @ 40 amps
6. Thermal resistance and power dissipation based on coil resistance at 180°C
7. Curves are based on 1.6 watts at 23°C
8. When full lifetime is at high ambient and high load current, subtract 25°C from maximum allowable ambient temperature.

Ordering Information

Part Number	Contact Arrangement	Contact Material	Enclosure	Terminals
VF4-11 * 11	1 Form A	AgNi0.15	Dust cover	Quick connect
VF4-11 * 13	1 Form A	AgNi0.15	Dust cover	Printed circuit
VF4-15 * 11	1 Form C	AgNi0.15	Dust cover	Quick connect
VF4-15 * 13	1 Form C	AgNi0.15	Dust cover	Printed circuit
VF4-25 * 11	1 Form C	AgNi0.15	Shrouded dust cover	Quick connect
VF435 * 11	1 Form C	AgNi0.15	Weatherproof cover	Quick connect
VF4-41 * 11	1 Form A	AgNi0.15	Dust cover with bracket	Quick connect
VF4-45 * 11	1 Form C	AgNi0.15	Dust cover with bracket	Quick connect
VF4-45 * 21	1 Form C	AgSnO	Dust cover with bracket	Quick connect
VF4-51 * 11	1 Form A	AgNi0.15	Shrouded dust cover with bracket	Quick connect
VF4-55 * 11	1 Form C	AgNi0.15	Shrouded dust cover with bracket	Quick connect
VF4-61 * 11	1 Form A	AgNi0.15	Weatherproof cover with bracket	Quick connect
VF4-65 * 11	1 Form C	AgNi0.15	Weatherproof cover with bracket	Quick connect
VF4-81 * 11	1 Form A	AgNi0.15	Dust cover with molded bracket	Quick connect
VF4-85 * 11	1 Form C	AgNi0.15	Dust cover with molded bracket	Quick connect

*Standard Coil Voltages: D = 6VDC (Consult factory for availability).
F = 12VDC
H = 24VDC (Consult factory for availability).

Optional Coil Suppression

Add suffix -S07 for 180 ohm resistor in parallel with 6VDC coil.
Add suffix -S01 for 680 ohm resistor in parallel with 12VDC coil.
Add suffix -S08 for 2,700 ohm resistor in parallel with 24VDC coil.

Epoxy Sealed Construction

Add suffix -C01 for epoxy sealed unit.
Add suffix -C05 for epoxy sealed unit with resistor.

Our authorized distributors are more likely to maintain the following items in stock for immediate delivery.

- VF4-15F11 VF4-15H11
- VF4-15F13 VF4-15H13
- VF4-45F11 VF4-65F11-S01

Outline Dimensions

Dust Cover With Quick Connect Terminals
VF4-1_ (Without Bracket) & VF4-4_ (With Bracket)

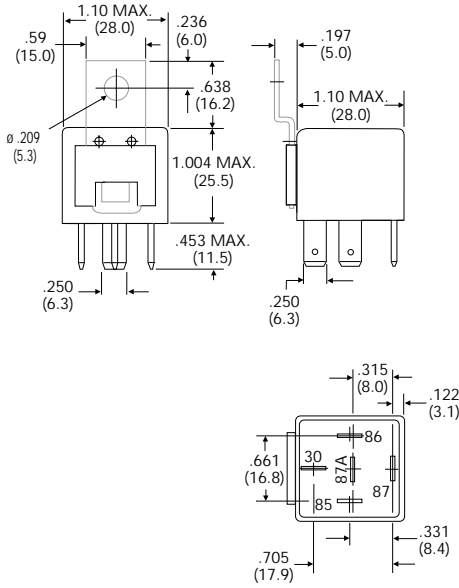

Plastic Bracket Cover With Quick Connect Terminals
VF4-8_

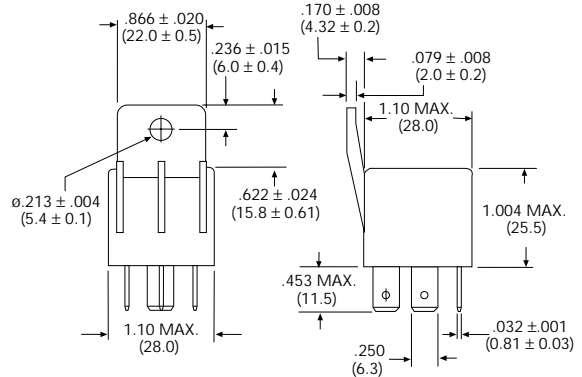

Printed Circuit Board Terminals
Clinchable Power

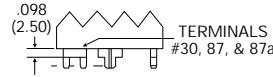

Single Pin

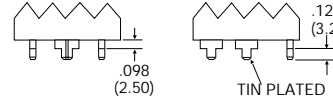

Shrouded Dust Cover With Quick Connect Terminals
VF4-2_ (Without Bracket) & VF4-5_ (With Bracket)

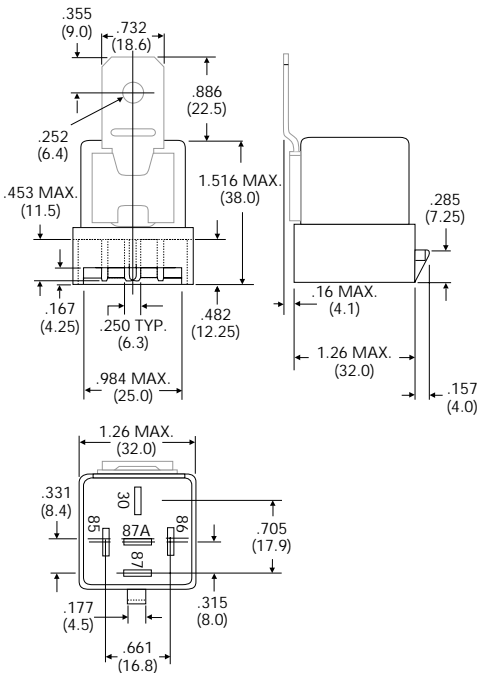

Weatherproof Cover With Quick Connect Terminals
VF4-3_ (Without Bracket) & VF4-6_ (With Bracket)

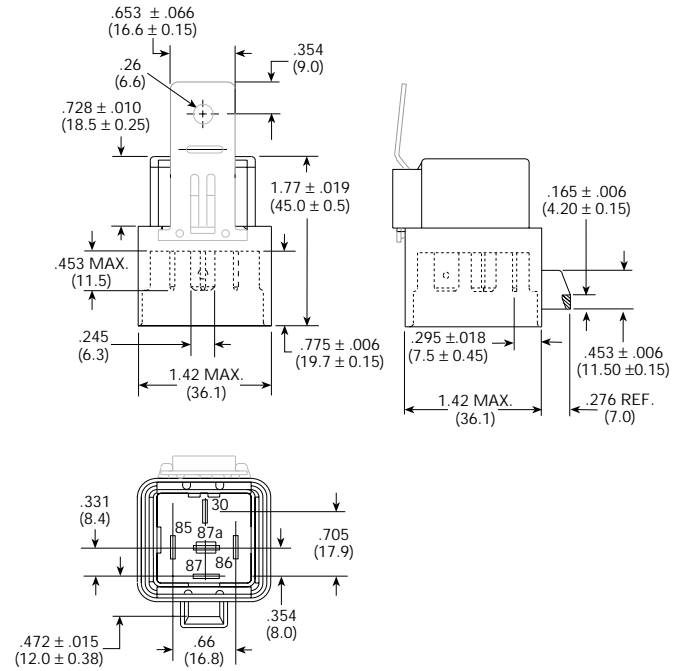

Wiring Diagrams (Bottom Views)

1 Form A

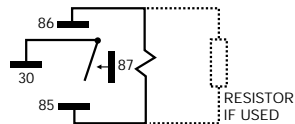

1 Form C

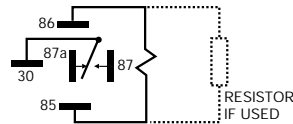

Suggested PC Board Layouts (Bottom Views)

VF4-XXX13

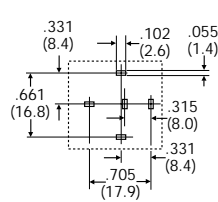

VF4-XXX12

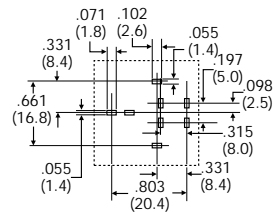

Connectors

Connectors For Use With Quick Connect Terminal VF4-1, VF4-4 And VF4-8 Relays

**PC Board Socket
VCF4-1000**

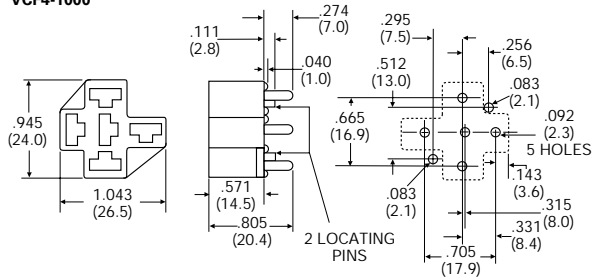

**Wiring Harness Style Connector (order terminals separately)
VCF4-1001**

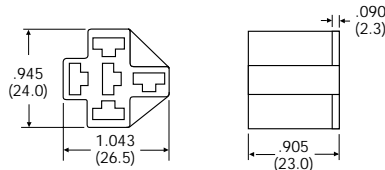

**Wiring Harness Style, Bracket Mount Socket (order terminals separately)
(Mount individually or can be interlocked)
VCF4-1002**

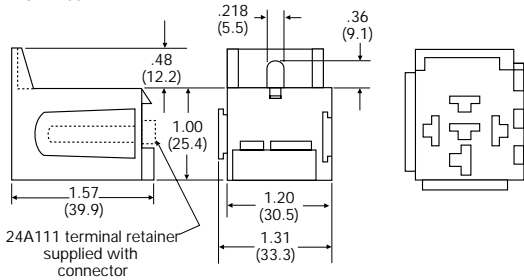

**Connector For Use With VF4-2 or VF4-5 Relays With Shrouded Dust Cover (order terminals separately)
VCF4-1003**

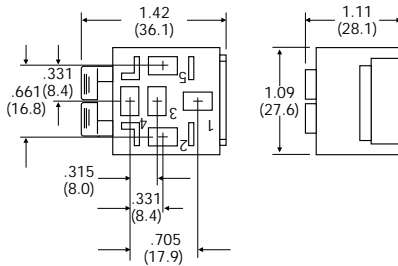

Connector For Use With VF4-3 or VF4-6 Relays With Weatherproof Cover
Connectors to mate with the weatherproof cover relays are available from Delphi Packard (1-800-PACKARD).
(Typical Delphi Packard part number: 12065685).

Connector/Terminal Usage Chart - Our authorized distributors are more likely to stock boldface items.

Connector	Terminal P/N	Required Crimp Terminals (Order Separately)			
		Alternate P/N	Wire AWG	Qty. Required	
				Form A	Form C
VCF4-1000	None	None	N/A	0	0
VCF4-1001	26A1349A	AMP 60249-1	12-16	4	5
	26A1349B	AMP 42281-1	14-18		
VCF4-1002 VCF4-1003	26A1348A	Packard 12015864	18-20		
	26A1348B	Packard 12015865	14-16	4	5
	26A1348C	Packard 12084588	10-12		



VF7 series

70 Amp Relay With PC Board or Quick Connect Terminals for Automotive Applications

Users should thoroughly review the technical data before selecting a product part number. It is recommended that users also seek out the pertinent approvals files of the agencies/laboratories and review them to ensure the product meets the requirements for a given application.

Features

- 70A continuous contact rating @ 85°C.
- 1 Form A arrangements.
- Plug-in or PC board terminals.
- Optional mounting bracket.

Conditions

All parametric, environmental and life tests are performed according to EIA Standard RS-407-A at standard test conditions (23°C Ambient, 20-50% RH, 29.5 ± 1.0" Hg.) unless otherwise noted.

Contact Data

Arrangements: 1 Form A (SPST-NO).
Material: AgNi 0.15 (consult factory for other contact materials).
Max. Switching Rate: 20 operations per second with no contact load.
 6 operations per minute for rated life at rated load.
Max. Switching Voltage: 75VDC⁽¹⁾.
Max. Load Current (@ 14VDC Load Voltage):
 Max. Continuous Current: 70A.
 Max. Make Current: 120A⁽²⁾.
 Max. Break Current⁽¹⁾: 70A.
Max. Switching Power: 60-800 watts DC (voltage dependent)⁽¹⁾.
Min. Recommended Current: 1 amp @ 12VDC.
Initial Voltage Drop: 200 millivolts, max., @ 70 amp contact load.
Expected Life: 10 million operations, mechanical; 100,000 operations at 70 amps, 14VDC, resistive load.

Initial Dielectric Strength

Between Contacts and Coil: 500V rms.

Coil Data

Voltage: 12 and 24VDC.
Resistance: See Coil Data table.
Nom. Power: (@ 23°C coil temp. and rated coil voltage):
 2.0W, un-suppressed.
 2.21W, with 680 ohm resistor.
Thermal Resistance: 50°C per actual coil watt in still air with no contact load current.

Coil Data (@ 23°C Coil Temperature)

Coil Designator	Rated Coil Voltage (VDC)	Coil Resistance ±10% (Ohms)	Coil Inductance (H) (Ref)	Must-Operate Voltage (VDC)	Must-Release Voltage (VDC)	Allowable ⁽³⁾ Overdrive (VDC)	
						@ 23°C	@ 85°C
F	12	72	0.5	7.2	1.2	18.1	14.1
H	24	288	2.0	14.4	2.4	36.2	28.2

Operate Data

Must Operate and Must Release Voltage: See Coil Data table.
Initial Operate Time: 7 milliseconds, typical, with rated coil voltage applied.
Initial Release Time: 2 milliseconds, typical, with zero volts applied (for un-suppressed relays after having been energized at rated coil voltage).

Environmental Data

Temperature Range: Storage: -40°C to +155°C.
Operating: -40°C to +125°C⁽⁴⁾.
Shock: 20g, 11 milliseconds, half sine wave pulse.
Vibration: (For NC contacts, NO contacts are significantly higher.)
 10-40 Hz., 1.27mm double amplitude.
 40-70 Hz., 5g's constant.
 70-100 Hz., 0.5mm double amplitude.
 100-500 Hz., 10g's constant.

Mechanical Data

Termination: 0.250" and 0.375" quick connect and printed circuit terminals.
Enclosures: Plastic dust cover.
Cover Retention: Cover will withstand a 33.7 pound (150 Newton) force (axially applied) without detachment.
Weight: 31g (1.1 oz.) approximately.

Abnormal Operation

Overload Current: 140A, 60 sec.⁽⁵⁾
 245A, 2 sec.
 420A, 0.15 sec.
24V Jump Start: 24VDC for 5 minutes conducting rated contact current @ 23°C.
Drop Test: Capable of meeting specifications after a 1.0 meter drop onto concrete, (Sealed model only.)
Flammability: UL94-HB or better (meets FMVSS 302).

Notes

- (1) See Figure 1.
- (2) Inrush current for lamp load.
- (3) Allowable overdrive is rated at ambient temperature for 23°C or 85°C as stated with no load current flowing through the relay contacts and minimum coil resistance. Also see Figure 2 for maximum ambient temperature versus applied coil voltage.
- (4) See Figure 2.
- (5) Current and times are compatible with circuit protection by a typical 70A automotive fuse. Relay will make, carry and break the specified current.

Figure 1 - Limiting Curve for Power Load

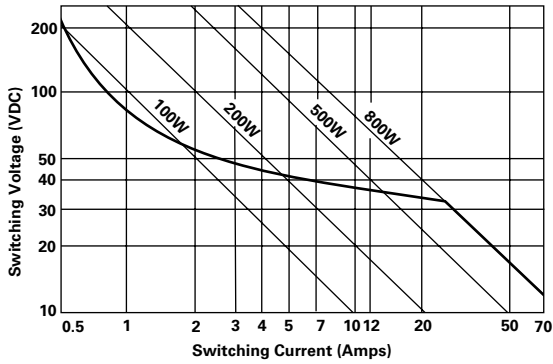

Safe breaking, arc extinguished (normally open contact) for resistive loads.

Figure 2 - Ambient Temperature vs. Coil Voltage for Continuous Duty

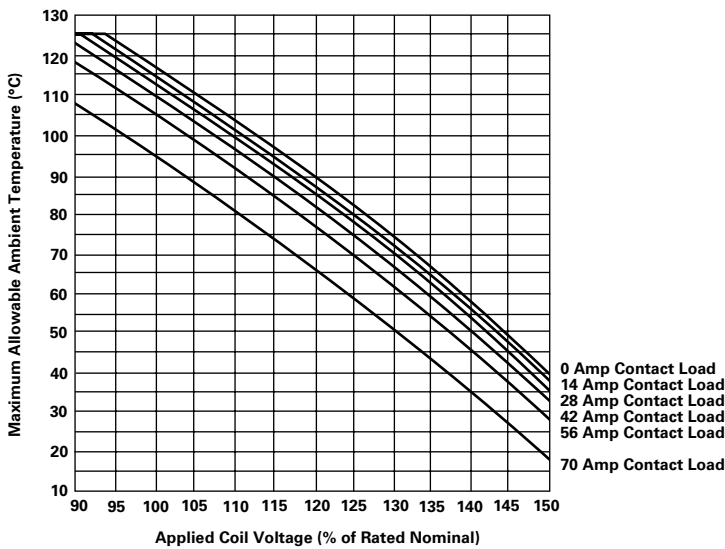

Assumptions:

1. Thermal resistance = 50°C per watt
2. Still air
3. Nominal coil resistance
4. Maximum mean coil temperature = 180°C
5. Coil temperature rise due to load
 - = 2°C @ 14 amps
 - = 4°C @ 28 amps
 - = 7°C @ 42 amps
 - = 12°C @ 56 amps
 - = 22°C @ 70 amps
6. Thermal resistance and power dissipation based on coil resistance at 180°C
7. Curves are based on 2.0 watts at 23°C
8. When full lifetime is at high ambient and high load current, subtract 25°C from maximum allowable ambient temperature.

Ordering Information

Part Number	Contact Arrangement	Enclosure	Terminals
VF7-11_*_11	1 Form A	Dust cover	Quick connect
VF7-11_*_12	1 Form A	Dust cover	Printed circuit (clinch)
VF7-41_*_11	1 Form A	Dust cover with bracket	Quick connect

*Standard Coil Voltages: F = 12VDC
H = 24VDC (Consult factory for availability)

Optional Coil Suppression

Add suffix -S01 for 680 ohm resistor in parallel with 12VDC coil.
Add suffix -S08 for 2700 ohm resistor in parallel with 24VDC coil.

Epoxy Sealed Construction

Add suffix -C01 for epoxy sealed unit.

Our authorized distributors are more likely to maintain the following items in stock for immediate delivery.

- VF7-11F11
- VF7-11F12
- VF7-41F11



VTF series

Flasher Modules for Automotive Applications

Safety Standards:

U.S.A.:

- SAE J 590 (turn signal)
- SAE J 945 (hazard warning)
- SAE J 2068 (turn signal/hazard warning)
- FMVSS 108 (all)

European:

Designed to meet ECO guideline 76/756 requirements.

Users should thoroughly review the technical data before selecting a product part number. It is recommended that users also seek out the pertinent approvals files of the agencies/laboratories and review them to ensure the product meets the requirements for a given application.

Features

- Combination turn signal and hazard warning signal flasher.(1)
- Meets all applicable U.S.A. safety standards.
- Stable electronic timing.
- VKP relay with PdCu contact for output.
- Fits ISO 7588 socket.
- Wide operating voltage and temperature range.

Conditions

All parametric, environmental and life tests are performed according to EIA Standard RS407-A at standard test conditions (23°C Ambient, 20-50% RH, 29.5 ± 1.0" Hg.) unless otherwise noted.

Contact Load Requirements @ 12.8VDC

Loads	Turn Signal Mode	Hazard Mode
	5 Lamp System	5 Lamp System
Rated Loads	5x27W + 1x3.5W + 1x1.3W	10x27W + 2x3.5W + 2x1.3W

Flash Rate and Duty Cycle Data

Turn Signal Mode		Hazard Mode	
Normal Signal		Normal Signal	
FPM	Duty Cycle	FPM	Duty Cycle
70-110	35-55%	70-110	35-55%

Operate Data

Nominal Voltage: 12VDC system.

Operating Voltage Range: 9 - 16VDC.

Device Voltage Drop: Less than 0.400 VDC at rated turn signal load.
Less than 0.450 VDC at rated hazard signal load.

Initial Turn-on Time: Less than or equal to 50 msec.

Start Time: Less than 1.0 sec per FMVSS 108.

Sound Pressure Level : Min. 72 dbA at 1.0 meters.(2)

Ordering Information

Part Number	Meets the Safety Standard of:	Flasher Type		Turn Signal Mode	Max. Number of Lamps	Lamp Outage Sensing
	U.S.A.	Turn	Turn/Hazard Warning	5 Lamp System	Hazard	No
VTF-11F31	X	X				
VTF-14F11	X		X	X	10	X

Our authorized distributors are more likely to maintain the following items in stock for immediate delivery.

None at present.

Environmental Data

Operating Ambient Temperature Range: -40°C to +85°C.

Storage Ambient Temperature Range: -40°C to +125°C.

Shock: 20g, 10 millisecond, half sine wave pulse.

Vibration: 10-40 Hz., 1.27mm double amplitude.
40-70 Hz., 5g's constant.
70-100 Hz., 0.5mm double amplitude.
100-500 Hz., 10g's constant.

Mechanical Data

Termination: 0.250" (6.35mm) quick connect.

Enclosures:

Dust Cover: Protects relay from dust.

Cover Retention: 50 pound (220 Newton) minimum.

Weight: 1.3 oz. (37g) approximately.

Abnormal Operation

Drop Test: Capable of meeting specifications after a 3.28 foot (1.0 meter) drop onto concrete in final enclosure.

Flammability: UL94-HB or better (meets FMVSS 302).

Notes

- (1) Three lamp combination flashers with three terminals do not meet U.S. Federal motor vehicle safety requirements when lamp outage occurs during hazard mode operation. For more information consult factory.
- (2) The actual sound pressure is highly dependent on mounting method used.

Figure 1 - Electrical Contact Life vs. Load Power

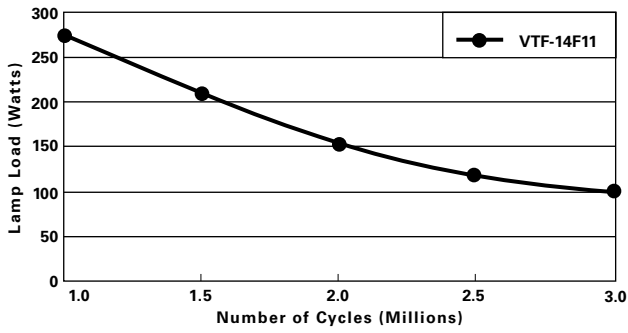

Wiring Diagram (Bottom View)

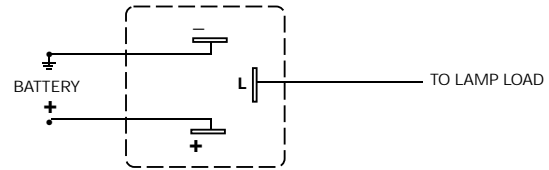

Outline Dimensions

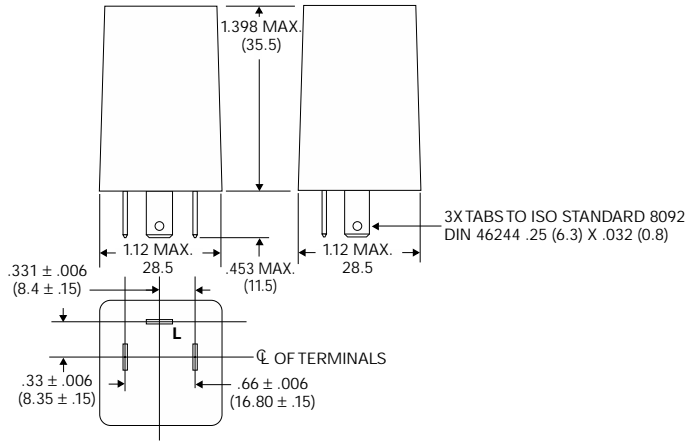

Connectors

**Wiring Harness Style Connector
(order terminals separately)
VCF4-1001**

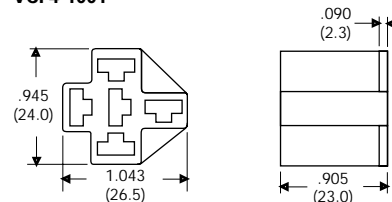

Sockets

**PC Board Socket
VCF4-1000**

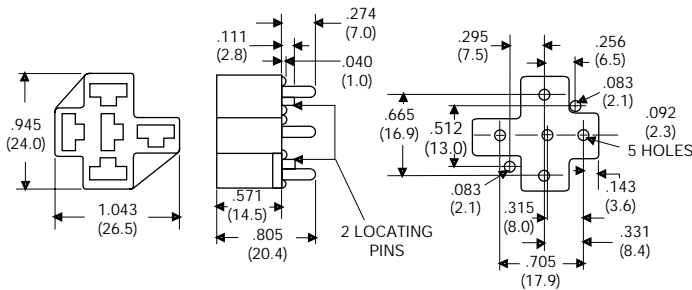

**Wiring Harness Style, Bracket Mount Socket
(order terminals separately)
VCF4-1002**

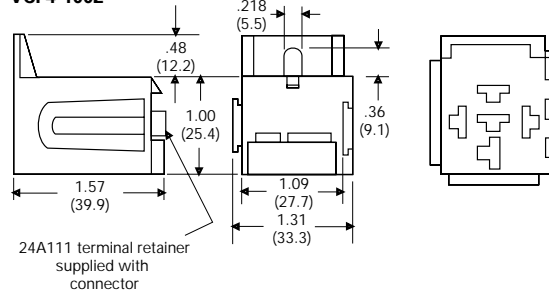

Connector/Terminal Usage Chart - Our authorized distributors are more likely to stock boldface items.

Connector	Required Crimp Terminals (Order Separately)			
	Terminal P/N	Alternate P/N	Wire AWG	Qty. Required
VCF4-1000	None	None	N/A	0
VCF4-1001	26A1349A	AMP 60249-1	12-16	3
	26A1349B	AMP 42281-1	14-18	
VCF4-1002	26A1348A	Packard 12015864	18-20	3
	26A1348B	Packard 12015865	14-16	
	26A1348C	Packard 12084588	10-12	

Engineering Notes

